

Panasonic Omnivision **VHS**

Video Cassette Recorder



Operating Instructions

MODELS **PV-9664/PV-9668**

Basic Operation

Advanced Operation

For Your Information

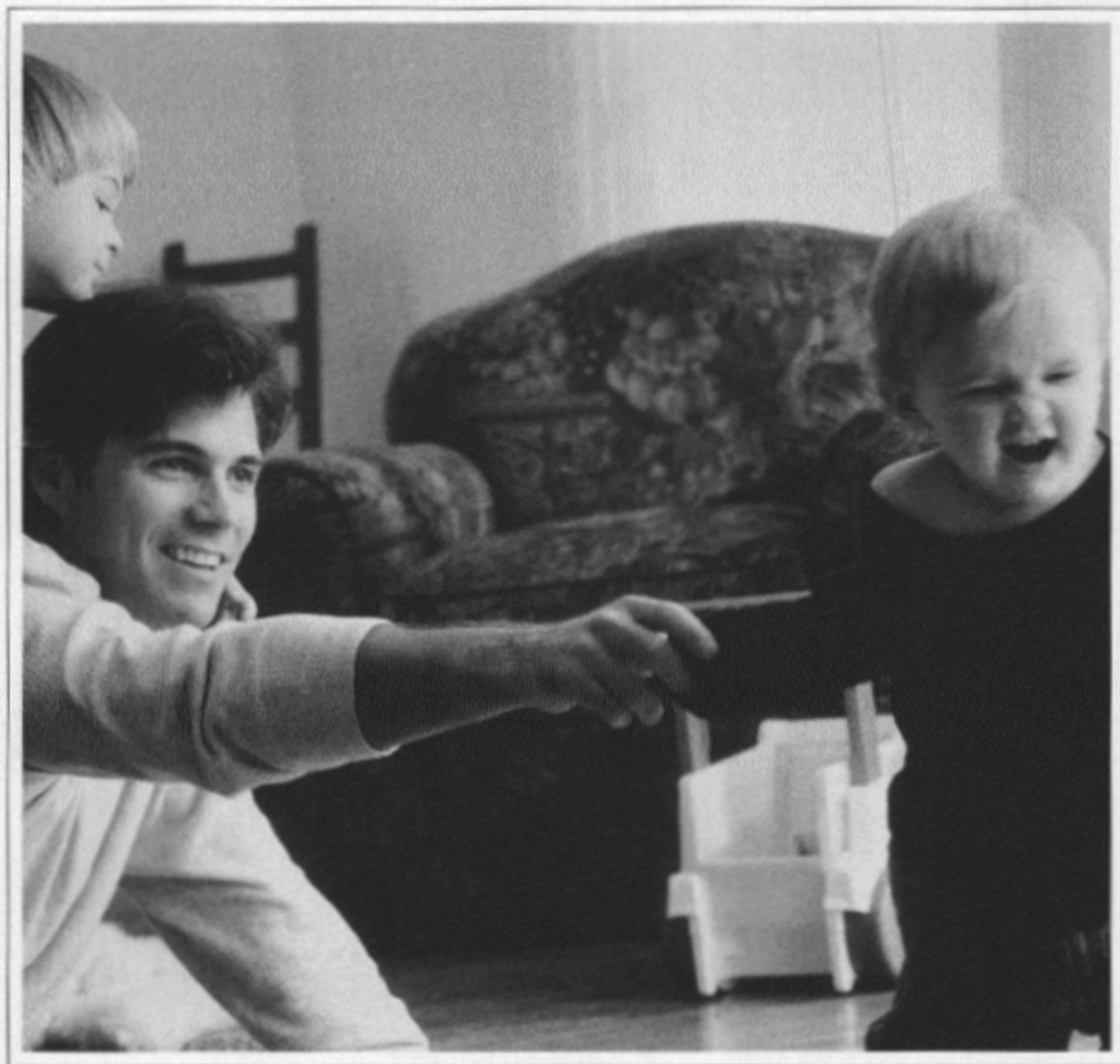

Please read these instructions carefully before attempting to connect, operate or adjust this product. Please save this manual.

Spanish Quick Use Guide is included. (Guía para rápida consulta en español está incluida.)

Quick Use Guide is on the back cover.

As an **ENERGY STAR**® Partner, Matsushita Electric Corporation of America has determined that this product or product model meets the **ENERGY STAR**® guidelines for energy efficiency.

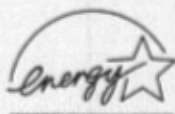

(PV-9668 only)



For assistance, call 1-800-211-PANA(7262).



Important Safeguards and Precautions

FOR YOUR SAFETY, READ AND RETAIN ALL SAFETY AND OPERATING INSTRUCTIONS. HEED ALL WARNINGS IN THE MANUAL AND ON THE UNIT

INSTALLATION

1 POWER SOURCE CAUTION

Operate only from a power source indicated on the unit or in this manual. If necessary, have your Electric Utility Service Company or Video Products Dealer verify the power source in your home.

2 POLARIZED OR GROUNDING PLUG

As a safety feature, this Video product comes with either a polarized power cord plug (one blade is wider than the other), or a three-wire grounding type plug.

POLARIZED PLUG CAUTION:

This plug will only fit into an outlet one way. If you cannot fully insert the plug, try reversing it. If it still will not fit, have an electrician install the proper wall outlet. Do not defeat the safety feature by tampering with the plug.

GROUNDING PLUG CAUTION:

This plug will only fit into a three-hole grounding outlet. If necessary, have an electrician install the proper outlet. Do not defeat the safety feature by tampering with the plug.

3 POWER CORD

Make sure power cords are routed so that they are not likely to have anything rest on them, roll over them, or be in the way of walking traffic. If an extension cord is used, make sure it also has either a polarized or grounded plug and that the cords can be securely connected. Frayed cords, damaged plugs, and damaged or cracked wire insulation are hazardous and should be replaced by a qualified service technician. Overloaded outlets and extension cords are fire hazards and should be avoided.

4 DO NOT BLOCK VENTILATION HOLES

Ventilation openings in the cabinet release heat generated during operation. If they are blocked, heat build-up inside the unit can cause failures that may result in a fire hazard or heat damage to cassettes. For protection, follow these rules:

- Never cover ventilation slots or the unit while in use, or operate the unit when placed on a bed, sofa, rug, or other soft surface.
- Avoid built-in installation, such as a book case or rack, unless proper ventilation is provided.

5 AVOID EXTREMELY HOT LOCATIONS OR SUDDEN TEMPERATURE CHANGES

Do not place the unit over or near any kind of heater or regulator, in direct sunlight, inside a closed vehicle, etc.. Do not move the unit suddenly between areas of extreme temperature variation. If the unit is suddenly moved from a cold place to a warm place, moisture may condense in the unit and on the tape.

6 TO AVOID PERSONAL INJURY

- Do not place unsecured equipment on a sloping surface.
- Do not place this unit on any support that is not firm, level, and adequately strong. The unit could fall causing serious injury to a child or adult and damage to the unit.
- An appliance and cart combination should be moved with care. Quick stops, excessive force, and uneven surfaces may cause the appliance and cart combination to overturn.
- Carefully follow all operating instructions and use the manufacturer's recommended accessories when operating this unit or connecting it to any other equipment.



Safety Precautions

Warning: To prevent fire or shock hazard, do not expose this equipment to rain or moisture.



This symbol warns the user that uninsulated voltage within the unit may have sufficient magnitude to cause electric shock. Therefore, it is dangerous to make any kind of contact with any inside part of this unit.

This symbol alerts the user that important literature concerning the operation and maintenance of this unit has been included. Therefore, it should be read carefully in order to avoid any problems.

OUTDOOR ANTENNA INSTALLATION

1 SAFE ANTENNA AND CABLE CONNECTION

If an outside antenna or cable system is connected to the equipment, be sure the antenna or cable system is grounded so as to provide some protection against built up static charges and voltage surges.

Section 810 of the National Electrical Code, ANSI/NFPA 70 (in Canada, part 1 of the Canadian Electrical Code) provides information with respect to proper grounding of the mast and supporting structure, grounding of the lead-in wire to an antenna discharge unit, size of grounding conductors, location of antenna discharge unit, connection to grounding electrodes and requirements for the grounding electrode.

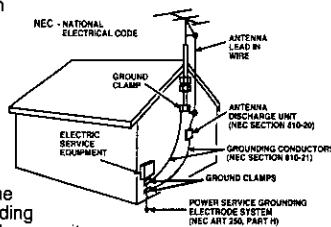

2 KEEP ANTENNA CLEAR OF HIGH VOLTAGE POWER LINES OR CIRCUITS

An outside antenna system should be located well away from power lines, electric light or power circuits and where it will never come into contact with these power sources if it should happen to fall. When installing an outside antenna, extreme care should be taken to avoid touching power lines, circuits or other power sources as this could be fatal. Because of the hazards involved, antenna installation should be left to a professional.

USING THE VIDEO UNIT

If the unit has been in storage or moved to a new location, refer first to the INSTALLATION section of these safeguards.

1 KEEP THIS VIDEO UNIT AWAY FROM WATER OR MOISTURE OF ANY KIND.

2 IF EQUIPMENT IS EXPOSED TO RAIN, MOISTURE, OR STRONG IMPACT, unplug the unit and have it inspected by a qualified service technician before use.

3 DURING AN ELECTRICAL STORM

During a lightning storm, whether indoors or outdoors, or before leaving the unit unused for extended periods of time, disconnect all equipment from the power source as well as the antenna and cable system.

4 WHEN THE UNIT IS PLUGGED IN

- Never expose the unit to rain or water. DO NOT OPERATE if liquid has been spilled into the unit. Immediately unplug the unit, and have it inspected by a service technician. Fire and shock hazards can result from electrical shorts caused by liquid contact inside.
- Never drop or push any object through openings in the unit. Some internal parts carry hazardous voltages and contact can cause electric shock or fire hazard.
- Avoid placing the unit directly above or below your TV set as this may cause electrical interference. Keep all magnets away from electronic equipment.

5 USING ACCESSORIES

Use only accessories recommended by the manufacturer to avoid risk of fire, shock, or other hazards.

6 CLEANING THE UNIT

Unplug the unit. Then, use a clean, dry, chemically untreated cloth to gently remove dust or debris. DO NOT USE cleaning fluids, aerosols, or forced air that could over-spray, or seep into the unit and cause electrical shock. Any substance such as wax, adhesive tape, etc. may mar the cabinet surface. Exposure to greasy, humid, or dusty areas may adversely affect internal parts.

SERVICE

1 DO NOT SERVICE THIS PRODUCT YOURSELF

If, after carefully following the detailed operating instructions, this Video product does not operate properly, do not attempt to open or remove covers, or make any adjustments not described in the manual. Unplug the unit and contact a qualified service technician.

2 IF REPLACEMENT PARTS ARE REQUIRED

Make sure the service technician uses only parts specified by the manufacturer, or those having the same safety characteristics as the original parts. The use of unauthorized substitutes may result in fire, electric shock, or other hazards.

3 HAVE THE SERVICE TECHNICIAN PERFORM A SAFETY CHECK

After any service or repairs to the unit, request the service technician to conduct a thorough safety check as described in the manufacturer's service literature to insure that the video unit is in safe operating condition.

Table of Contents

Use
Now!

Important Safeguards and Precautions	2
Accessories	4
Loading the Batteries	4
Basic Connections (Antenna, VCR, TV)	4, 5
One Time VCR Setup (Language, Cable/ DSS, Channels, Clock) ..	6 ~ 11
Playback a Tape (Slow Motion, Still Picture, Frame by Frame)	12
Record On a Tape	13
• One Touch Recording	13

Basic Operation

Enjoy
more!

Advanced Connections (Cable/DSS, Audio/Video)	14, 15
Timer Recording	16, 17
• Timer Recording	16
• Review, Replace or Clear Program Contents	17
Timer Recording Using VCR Plus+ System	18 ~ 21
• Auto VCR Plus+ System Channel Setup	18, 19
• Manual VCR Plus+ System Channel Setup	20
• Programming	21
Multi-Brand Control Feature	22, 23
Tape Operation	24 ~ 30
• Commercial Advance	24 ~ 26
• Auto Operation Functions	29
• Movie Advance	27
• Repeat Play	30
• VHS Index Search System	28, 29
• Zero Search	30
Copying Your Tapes (Dubbing)	31
MTS Broadcast/ VHS Hi-Fi Stereo System	32, 33
• Stereo/SAP/Mono Broadcast	32
• Spatializer (PV-9668 only)	33
• Select Audio Mode	33
Special VCR Features	34 ~ 39
• Channel Caption	34, 35
• VCR Lock	38
• Time Stamp	36, 37
• Weak Signal Display ON/OFF	39
• Tape Position Display	38
• Auto Shut-Off	39
• Remote Warning ON/OFF	38

Advanced Operation

Other
Information!

Reset Language, Channels, Clock	40, 41
VCR & Cassette Information	42, 43
• Reset All VCR Memory Functions ..	42
• Head Cleaning	43
• DST (Daylight Saving Time) ...	42
• Cleaning the VCR	43
• Prevent Accidental Tape Erasure ..	42
• Specifications	43
• Record/Playback Time	42
• Features for Quality	43
On-Screen Displays (OSD)	44
• Function & Channel Display	44
• Warning and Instruction Displays	44
• VCR Status & Clock Display ...	44
Before Requesting Service	45
Service Center List	46
Warranty	47
Spanish (Español) Quick Use Guide	48 ~ 51
Location of Controls	52, 53
Quick Use Guide (Playback, Recording)	Back Cover

For Your Information

Before Using

Basic Connection

Congratulations

on your purchase of one of the most sophisticated and reliable products on the market today. Used properly, it will bring you and your family years of enjoyment. Please fill in the information below. The serial number is on the tag located on the back of your VCR.

- Date of Purchase _____
- Dealer Purchased From _____
- Dealer Address _____
- Dealer Phone No. _____
- Model No. _____
- Serial No. _____

Accessories

Remote Control
VSQS1598

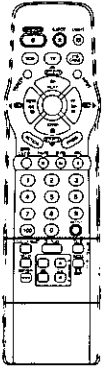

Batteries 2 "AA"

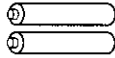

RF Coaxial Cable
VJAS0196



To order accessories, call toll free
1-800-332-5368.

Loading the Batteries

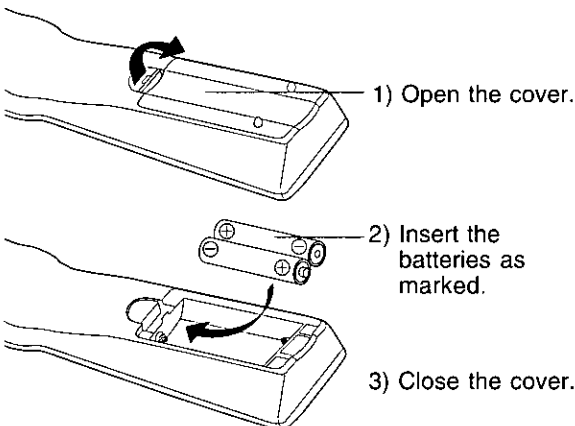

Battery replacement caution

- Do not mix old and new batteries.
- Do not mix alkaline with manganese batteries.

ANTENNA (See page 5)

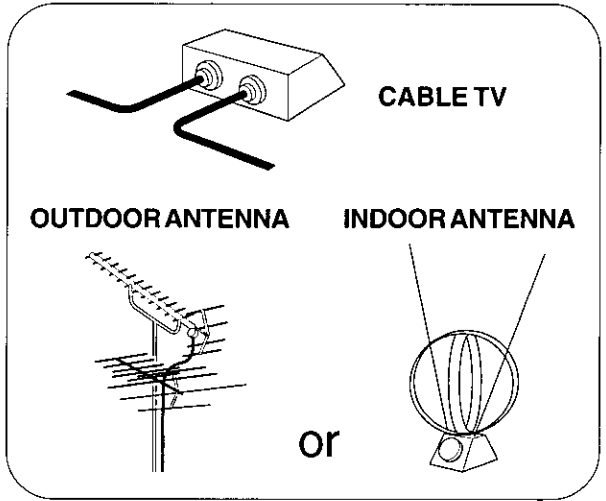

VCR

1 Disconnect antenna or cable from TV and connect to VCR.

IN FROM/ ANT

OUT TO TV

3 ch 4

3 Set VCR Output to channel 3 or 4 (not an active station).

2

Connect VCR to TV with RF Coaxial Cable.

VHF/UHF



TV

Tune TV to VCR output channel the same one you set in step 3.

WARNING

When using "Nut type" RF coaxial cables, tighten with fingers only. Overtightening may damage terminals.

1 Between ANT. and VCR

■ Case 1: Twin Lead Cable Only

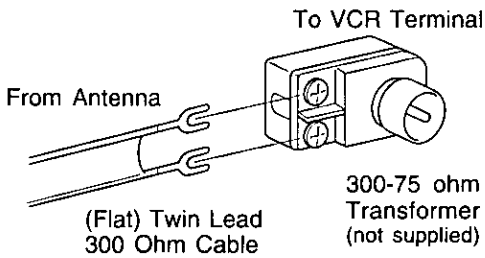

■ Case 2: Twin Lead & Coaxial Cables

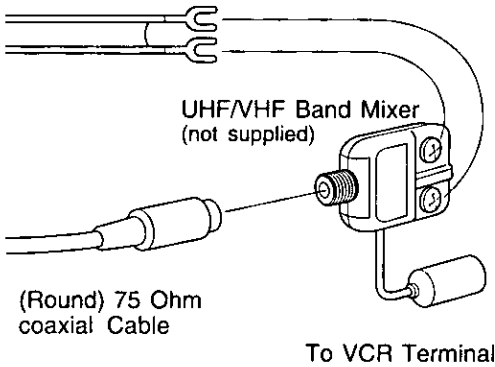

■ Case 3: Two Twin Lead Cables

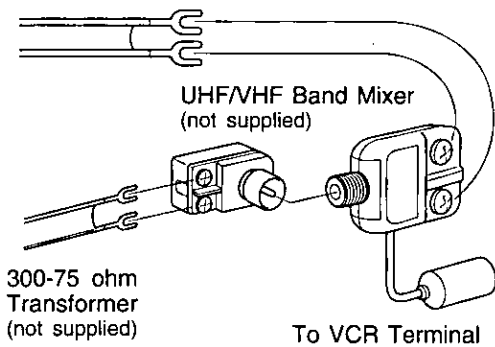

- If your TV has both post and plug-type VHF terminals, the post connection is recommended to minimize signal loss.

2 Between VCR and TV

■ Case 1: Screw & Plug Type Terminal

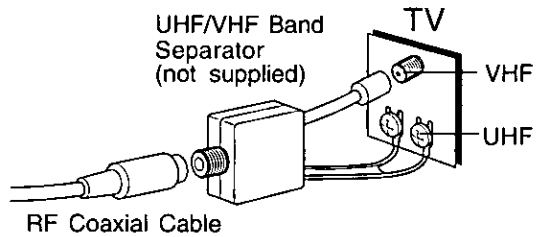

■ Case 2: Screw Type Terminal

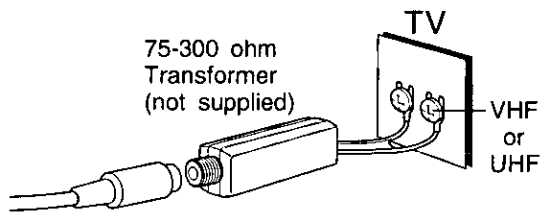

■ Case 3: Double Screw Type Terminal

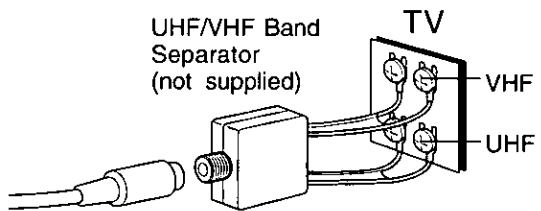

■ Case 4: Complex TV Terminal TERMINALS ON BACK OF TV SET

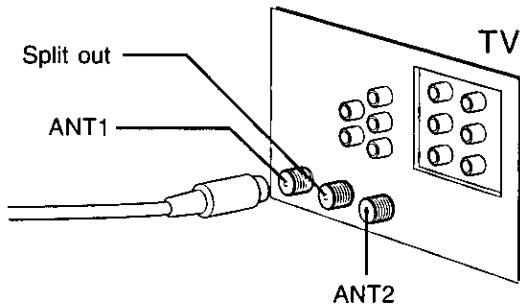

- Connect to one of the ANT terminals and select the same antenna number on the TV.

One Time VCR Setup

The setup on pages 8 through 11 is vital for proper VCR operation. Please read the instructions carefully and in the order presented.

NOTE: These first two pages contain reference material needed for setup on pages 8-11. Please look over the information before you begin setup procedure.

Setup Overview

You will be performing the following tasks:

- Setting the language you want on-screen displays to appear in (English, Spanish, French.)
- Telling the VCR what kind of equipment you are using to receive channels and how it is connected.
- Entering pertinent cable box or DSS receiver information if used.
- Entering a local PBS channel so that the VCR can receive auto clock set data. (Not available in all areas.)
- Placing channels in memory and setting the clock.

Please Note Which Connection Type You are Using.

Make sure all equipment is hooked up as described on pages 8-11. The diagrams below illustrate some of the basic connection types. Confirm which type you used for later reference.

Connection Type A

<Cable box → VCR → TV connection>

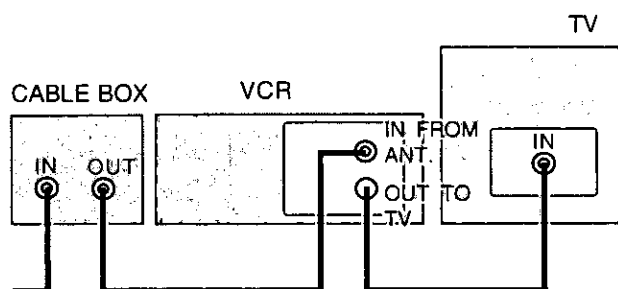

Connection Type B

<VCR → TV connection>

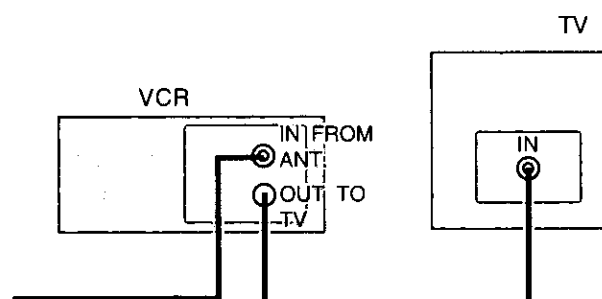

<DSS box → VCR → TV connection>

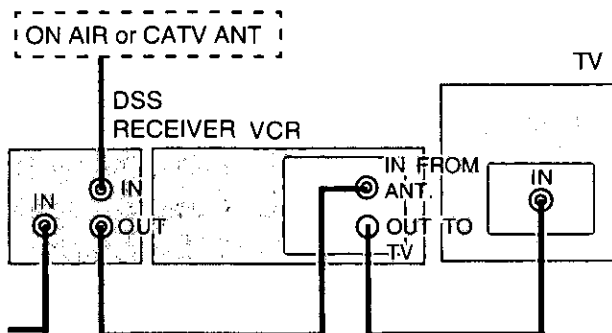

<VCR → Cable box → TV connection>

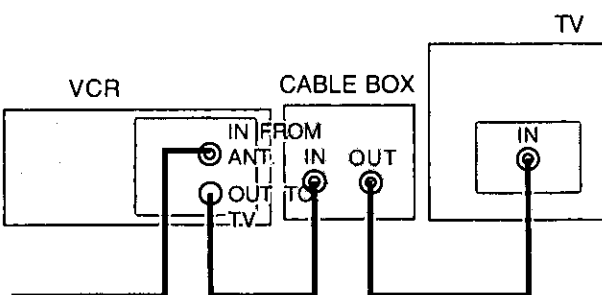

ONE TIME SETUP IMPORTANT NOTES:

- For detailed DSS receiver connection instruction, please see your DSS operating manual.
- The DSS receiver must be turned off to view programs from the cable box or antenna.
- If you use a DSS receiver, it must be turned off for auto clock set.
- If your cable box is not remote controllable, it must be tuned to your PBS channel.
- If you use Audio/ Video Jack connection between the VCR and cable box or DSS receiver, you must also connect the RF coaxial cable in order to use auto clock set and channel auto set features.

Important: If the remote control POWER, ACTION, PROG, CH ▲/▼, INDEX/ M/A SKIP, NUMBERED keys, INPUT, TAPE POSITION, or ADD/DLT button does not work when pressed, press the VCR button on the remote and try the button again.

Cable Box/ DSS Receiver Code Number List

If your cable box or DSS receiver is remote controllable, refer to this list during setup on page 8.

Cable Box

Brand	Code Number
Archer	01, 05, 06, 44, 63
Cabletenna	01, 44, 63
Cableview	04, 30, 42, 44, 52, 63
Century	44, 51, 59, 75
Citizen	04, 30, 42, 44, 52, 63
Components	32, 39, 42, 44
Curtis	08, 09, 53, 61
Diamond	01, 44, 63
Eagle	13, 20, 22, 26, 40, 58, 62
Eastern	28
GC Brand	04, 30, 42, 44, 52, 63
Gemini	04
General Electric	01, 57
General Instruments	01, 02, 03, 04, 34, 55, 65, 67, 68, 83
Hamlin	14, 15, 28, 41, 102, 103, 104
Hitachi	31, 79
Jasco	04
Jerrold	01, 02, 03, 04, 34, 55, 65, 67, 68, 83
Macom	31
Magnavox	26
Matsushita	16, 17
Movietime	32, 39, 42, 44
NEC	32, 38, 40
NOVAVISION	08, 09, 53, 61
NSC	32, 38, 40
Oak	11, 46, 101
Oak Sigma	11, 46, 101
Panasonic	16, 17
Philips	07, 13, 20, 23, 24, 50
Pioneer	05, 06
Pulsar	04, 30, 42, 44, 52, 63
Quest	05, 06
Radio Shack	44, 51, 59, 75
RCA	16, 17
Realistic	44, 51, 59, 75

Brand	Code Number
Recoton	44, 51, 59, 75
Regal	14, 15, 28, 41, 102, 103, 104
Regency	28
Rembran	01, 29, 32, 39, 42, 44, 63
Samsung	05, 06, 32, 40, 42
Scientific Atlanta	08, 09, 53, 61
Sheritech	27
Signal	26
SL Marx	06, 32, 40, 42, 43, 44, 52, 63
Spucer	16, 17
Standard Components	32, 39, 42, 44
Stargate	04, 06, 30, 32, 40, 42, 44, 52, 63
Sylvania	19
Teknika	74
Telecaption	77
Televue	06, 32, 40, 42
Texscan	18, 19
Tocom	01, 33, 34, 42, 66
Toshiba	36
Unika	01, 44, 63
Universal	42, 43, 44, 52, 63
Videoway	07, 23, 50
Vid Tech	64
Vidtek	36, 64
Viewstar	13, 20, 22, 26, 40, 58, 62
Zenith	07, 23, 50

DSS (Digital Satellite System Receiver)

Toshiba	92
Hitachi	93
Hughes	93
Magnavox/ Uniden 1	94
Magnavox/ Uniden 2	95
Panasonic	96
RCA	97
Sony	98, 105

Note

During setup you will be instructed to enter your brand code number. As some brands have multiple codes, it may be necessary to try different codes to attain the proper results. These codes are for Cable box or DSS Box setup for Auto Clock and VCR Plus+ recording only. For TV/ Cable Box Multi-Brand Control operation, please see page 22.

Positioning Your Cable Box or DSS Receiver

If your cable box or DSS receiver is remote controllable, place it on or near the VCR as shown in the example right. The VCR transmits an infrared signal from two locations. Be sure not to cover the transmitter windows.

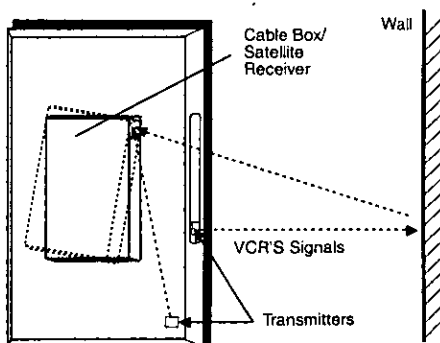

One Time VCR Setup (continued)

When VCR is turned on the first time.

- Setup mode is entered automatically.
- Self Demo Mode is started automatically on Multi Function Display. When you set the clock, it is canceled. (For details, see page 53.)

Process of Setup

Language → Cable/DSS Receiver

→ Channels → Clock

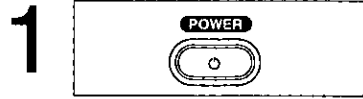

1 Turn the TV and VCR on. Press POWER.

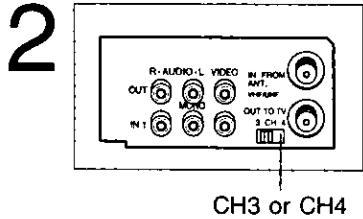

2 Tune to VCR output channel. Tune TV to CH3 or CH4. (Same as back of VCR)

- Always tune TV to this channel to monitor the VCR.
- If you used audio/video jack connection, tune the TV to its video input.

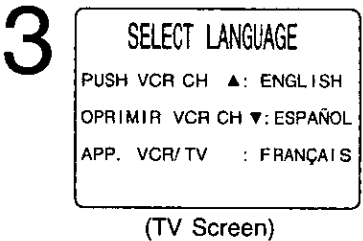
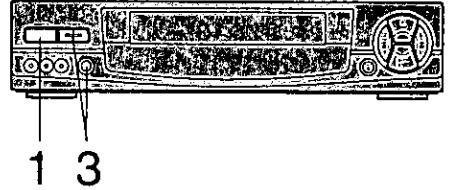

3 Select the language.

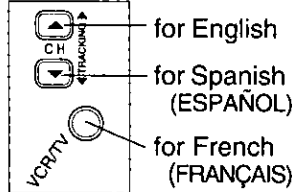

- Use remote or VCR buttons.
- If wrong language is set, do "Reset All VCR Memory Functions" steps on page 42.

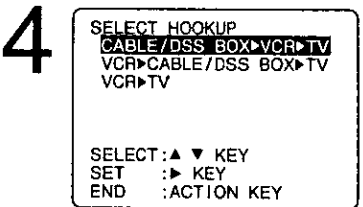
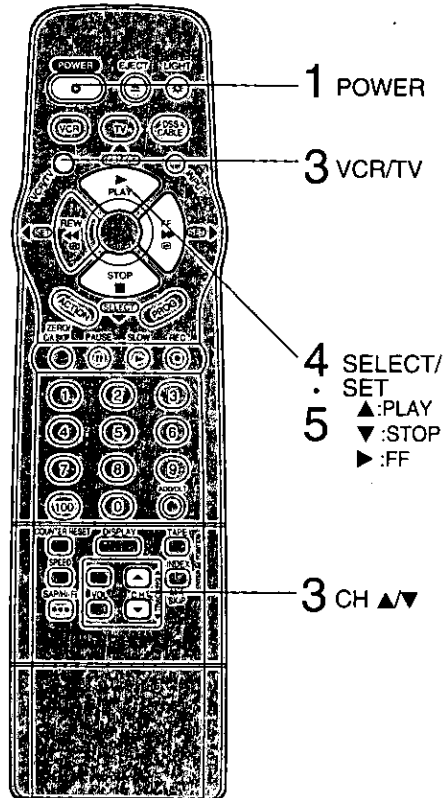

4 Select hookup.

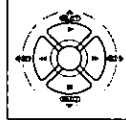

- 1) Press ▲▼ to select.
- 2) Press ► to set.

- If you selected "CABLE/ DSS BOX ▶ VCR ▶ TV," continue with step 5. (Only cable box output channel will be placed in memory.) If not, go to "Alternate Instructions" on page 11.

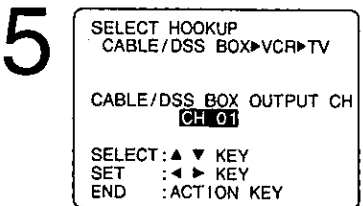

5 Select cable box or DSS receiver output channel.

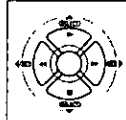

- 1) Press ▲▼ to select.
- 2) Press ► to enter.

- If necessary, refer to cable box manual.
- If you used Audio/ Video jack connection to cable box, set "VIDEO OUT."
- If both cable box and DSS receiver are used, set output channel of DSS receiver.

6

ENTER CODE NUMBER REFERRING TO MANUAL

01

SELECT: ▲ ▼ KEY
 SET : ► KEY
 END : ACTION KEY

Select cable box or DSS receiver code.
 (Refer to the list on page 7.)

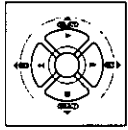

- 1) Press ▲▼ to select.
- 2) Press ► to enter.

- If cable box or DSS receiver has no remote control, select "NO REMOTE." Then, go to "Alternate Instructions" on page 11.
- This determines whether VCR will control cable box or DSS receiver.

7

If Cable Box

PLEASE TUNE YOUR CABLE BOX TO CH02.

If DSS Receiver

PLEASE TUNE YOUR DSS RECEIVER TO CH 270.

PROCEED: ► KEY
 END : ACTION KEY

Tune Cable box or DSS Receiver channel.

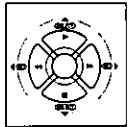

- 1) If Cable box, tune it to channel 02. If DSS receiver, tune it to channel 270.
- 2) Press ► to continue.

- "NOW TRANSMITTING" appears.

8

If Cable Box

IS YOUR CABLE BOX RECEIVING CH 09 ?

YES
 NO

If DSS Receiver

IS YOUR DSS RECEIVER RECEIVING CH 200?

YES
 NO

SELECT: ▲ ▼ KEY
 SET : ► KEY
 END : ACTION KEY

Set receiver channel.

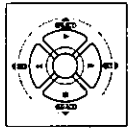

- 1) Press ▲▼ to select "YES" or "NO."
- 2) Press ► to enter.

If "YES" with cable box, go to step 9.

If "YES" with DSS receiver, go to "Alternate Instructions" on page 11.

If "NO," the screen in step 6 will appear. Try entering a different code and/ or repositioning the equipment (see page 7.)
 If still "NO," cable box or DSS receiver is not available.

For channel and clock auto set, press ACTION to display the "SET UP CHANNEL" screen. Then, press ▲▼ to select "AUTO SET."

Now, press ► and CH▲ to start.

9

PLEASE ENTER YOUR LOCAL PBS CHANNEL ON CABLE BOX

CH --

SELECT: ▲ ▼ KEY
 SET : ► KEY
 END : ACTION KEY

Confirm that cable box is on and that DSS receiver is off.

Select local PBS channel on cable box.

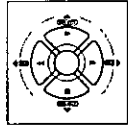

- 1) Press ▲▼ to select.
- 2) Press ► to set.

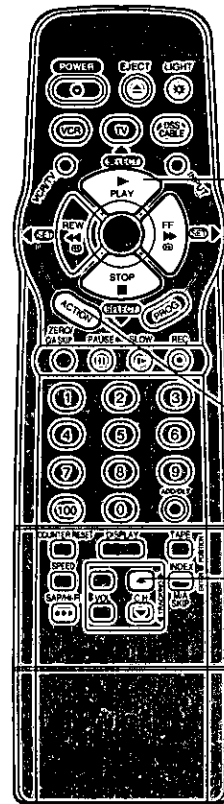

- 6. SELECT/SET
- 7. ▲:PLAY
- 8. ▼:STOP
- 9. ►:FF

ACTION

CH ▲

Continued on the next page...

One Time VCR Setup (continued)

10

CLOCK AUTO SET
 CONNECT ANTENNA CABLE
 AND IF YOU USE A CABLE
 BOX, TUNE IT TO YOUR
 LOCAL PBS CH THEN...
 PLEASE PUSH CH UP KEY

Start Clock Auto Set.

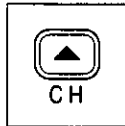

Press CH ▲.

- "AUTO CLOCK SET PROCEEDING" appears.

Process of Setup

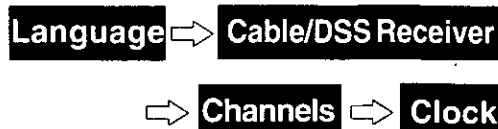

11

1/ 4/2000 TUE 12:00PM
 DST: ON
 SETTING : CH 02
 AUTO CLOCK SET
 COMPLETED
 END : PUSH CH UP KEY

Confirm that time is correct.

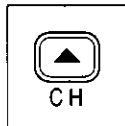

Press CH ▲ to exit.

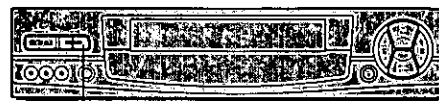

10-11

If displayed time is incorrect...

If your area observes DST (daylight saving time), but the time is incorrect; do "Time Zone Adjust" steps on page 41.

Or, if you use cable box and receive more than one PBS station, try auto clock set again entering the one you have not tried yet (See "To Set or Reset the Clock" on page 40.)

If the screen below appears...

Auto clock set data is not available in your area. Press ACTION to display Manual Clock Set screen, and then do steps b) ~ d) on page 11.

AUTO CLOCK SET
 IS INCOMPLETE
 PUSH ACTION TO SET CLOCK

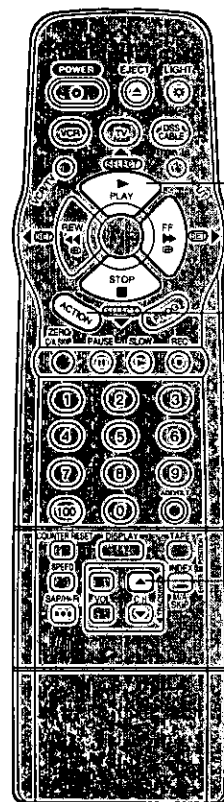

SELECT/
 SET
 ▲:PLAY
 ▼:STOP
 ►:FF

ACTION

10 CH ▲
 11

To Setup VCR in Case a Cable Box or DSS Receiver was Installed or Replaced.

a Press ACTION to display Menu.

b Press ▲▼ to select "SET UP CHANNEL," then press ►.

c Press ▲▼ to select "CABLE/ DSS BOX SET UP," then press ►.

d Press ▲▼ to select "CABLE/ DSS BOX ► VCR ► TV," then press ► to set.

e Continue with steps 5~8 on pages 8~9.

```

    ----- MENU -----
    SET UP VCR
    SET UP FEATURE
    SET CLOCK
    SET UP CHANNEL
    ID IOMA/LANGUE: ENGLISH
    SELECT: ▲ ▼ KEY
    SET : ► KEY
    END : ACTION KEY
    
```

```

    ----- SET UP CHANNEL -----
    ANTENNA : CABLE
    AUTO SET
    CHANNEL CAPTION
    WEAK SIGNAL DISPLAY : OFF
    CABLE/DSS BOX SET UP
    VCR Plus+ CH SET UP
    SELECT: ▲ ▼ KEY
    SET : ► KEY
    END : ACTION KEY
    
```

Using ▲▼◀▶ keys

You can also operate the menu screen using VCR buttons.

If you use VCR buttons, press CH ▲ and CH ▼ together to display the menu screen.

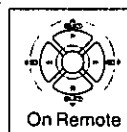

On Remote



On VCR

▲ : PLAY
 ▼ : STOP
 ◀ : REW
 ▶ : FF

When menu screens are displayed, PLAY, STOP, REWIND, and FF buttons function as ▲▼◀▶ only.

Note

Auto clock set will be performed when VCR is turned off the first time each day. Therefore, cable box must be left on and tuned to PBS channel before VCR power is turned off.

10

For assistance, call 1-800-211-PANA(7262).

***Important:** If the following buttons, ACTION, PROG, CH▲/▼, INDEX/M/A SKIP, NUMBERED keys, INPUT, TAPE POSITION, or ADD/HLT button does not work when pressed, press the VCR button on the remote and try the button again.

Alternate Instructions

complete steps below if any of the following applies:

- Selected connection type B (VCR ► CABLE/DSS BOX ► TV or VCR ► TV) in step 4, page 8.
- Selected "NO REMOTE" in step 6, page 9.
- Selected "YES" with DSS receiver in step 8, page 9.

1

CHANNEL/CLOCK AUTO SET

CONNECT ANTENNA CABLE AND IF YOU USE A CABLE BOX, TUNE IT TO YOUR LOCAL PBS CH THEN...

PLEASE PUSH CH UP KEY

Start Channel Auto Set and Clock Auto Set.

- The following messages appear. "CH AUTO SET PROCEEDING" "AUTO CLOCK SET PROCEEDING"

2

1/ 4/2000 TUE 12:00PM
DST:ON
SETTING : CH 02
AUTO CLOCK SET
COMPLETED
END : PUSH CH UP KEY

Confirm that time is correct.

Press CH ▲ to exit.

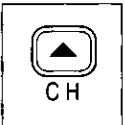
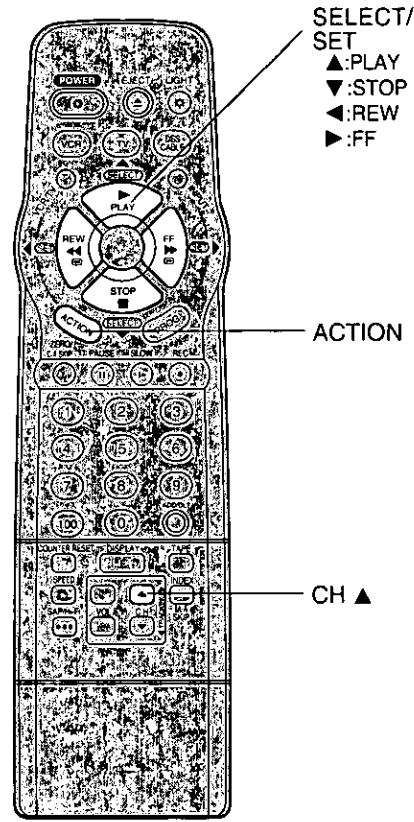
- SELECT/SET**
- ▲:PLAY
 - ▼:STOP
 - ◀:REW
 - ▶:FF

Clock Setup incomplete...

AUTO CLOCK SET IS INCOMPLETE

PUSH ACTION TO SET CLOCK

Set the clock manually.

a) Press ACTION.



SET CLOCK

1/ 4/2000 TUE 12:00PM
DST:ON

SELECT MONTH

SELECT:▲ ▼ KEY
SET :▶ KEY
END :ACTION KEY

b) Press ▲▼ to select month.

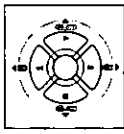

c) Press ▶ to set.

- Likewise, set date, year, time, DST (Daylight Saving Time).

SET CLOCK

1/ 4/2000 TUE 12:00PM
DST:ON

SET COMPLETED

SET :◀▶ KEY
START :ACTION KEY

To Make Corrections, repeatedly press ◀▶ to move to error, then correct.

d) Press ACTION. (Clock starts.)

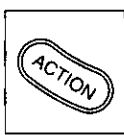

- To exit this mode, press ACTION again.

Note
If you use a DSS receiver, it must be turned off.

If displayed time and DST are incorrect...

If you use cable box and receive more than one PBS station, try auto clock set again entering the one you have not tried yet. (See "To Set or Reset the Clock" on page 40.)

If you happen to live close to two time zones, VCR may have recognized PBS channel (setting channel) in the wrong time zone. Please do the following to correct the situation.

- 1) Make a note of SETTING : CH number shown on screen and press CH ▲ to exit.
- 2) Delete the channel from VCR memory. (See "Add or Delete a Channel" on page 41.)
- 3) Press ACTION to display the menu.
- 4) Press ▲▼ to select "SET CLOCK," and then press ▶ to display the SET CLOCK screen.
- 5) Press ▲▼ and ▶ to select and set "AUTO CLOCK SET."
- 6) Follow One Time VCR Setup instructions on page 8-11.

- If you use cable box and have multiple PBS stations, tune cable box to a different PBS station and try auto clock set using the menu.

Playback a Tape

✓ Check list before you begin.

- All connections are made.
- TV and VCR are plugged in.
- TV is turned on and set to the VCR channel (CH 3 or 4).
- Remote is in VCR mode.

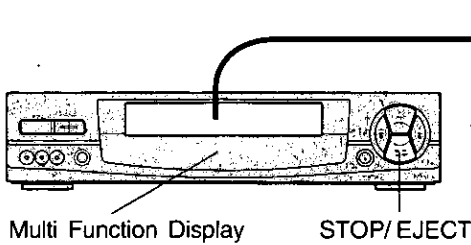

1

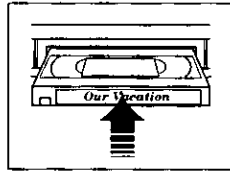

Insert a cassette.

- VCR power comes on and VCR appears on Multi Function Display.

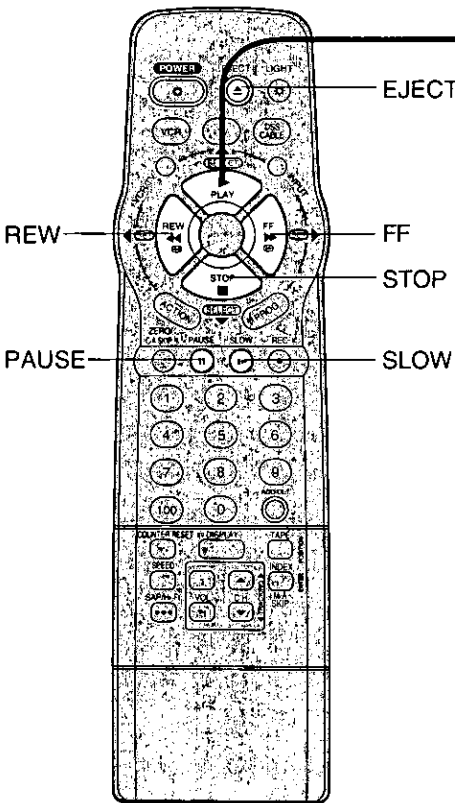

2



Press PLAY.

- Playback begins if cassette has no record tab.

- To Find a Particular Scene
Forward Search --> Press FF.
Reverse Search --> Press REW.
- For Slow Motion --> Press SLOW.
(To release, press SLOW.)
- For Still (Freeze) picture --> Press PAUSE.
(To release, press PAUSE.)
- For Frame by Frame picture --> Press SLOW in Still mode.
(To release, press PAUSE.)

Notes

- To reduce picture noise, see "Manual Tracking Control" on page 43.
- After the VCR is in Still or Slow mode for 3 minutes, it will switch to Stop mode automatically to protect the tape and the video head.

- To stop --> Press STOP.
- To rewind tape --> Press REW in Stop mode.
- To fast forward tape --> Press FF in Stop mode.
- To eject tape --> Press EJECT on the remote or STOP/ EJECT on the VCR.

Note

- To prevent tape jam
Inspect your cassette tapes and remove any loose or peeling labels.

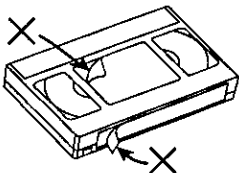

Playback using VCR controls

1 Insert a cassette.

2 Press PLAY.



- Press to stop and/or eject tape.

Record On a Tape

*Important:

If the remote control POWER, ACTION, PROG, CH ▲▼, INDEX/ M/A SKIP, NUMBERED keys, INPUT, TAPE POSITION, or ADD/HLT button does not work when pressed, press the VCR button on the remote and try the button again.



Multi Function Display

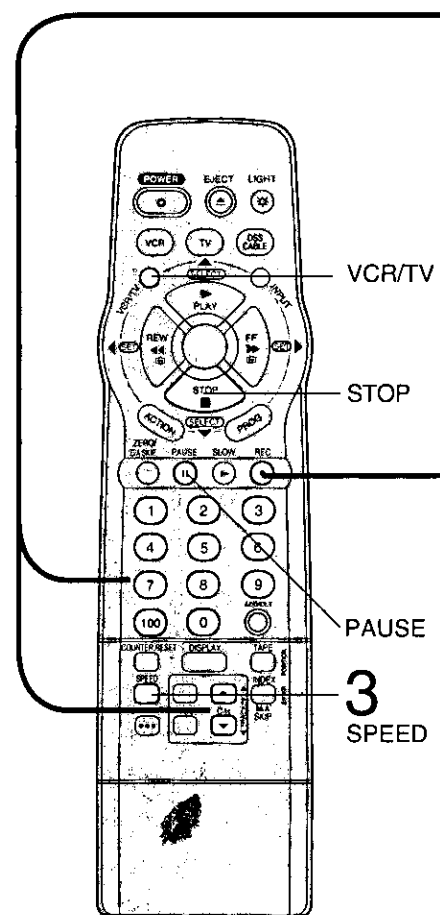

✓ Check list before you begin.

- All connections are made.
- TV is turned on and set to the VCR channel (CH 3 or 4).
- Cassette with record tab in place.
- Remote in VCR mode.

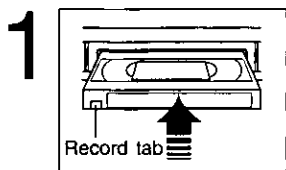

1 Insert a cassette.

- VCR power comes on automatically.

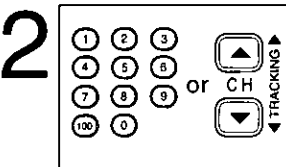

2 Select Channel.

Press CH ▲▼* or NUMBERED keys.

- To select "LINE", see page 31.
- To select channels over 100, first press 100 key, then enter remaining two digits.

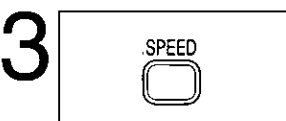

3 Select Recording speed.

(See page 42.)

Press SPEED.

- SP = Standard Play
- LP = Long Play
- SLP = Super Long Play
- Selected speed is displayed on TV screen and Multi Function Display.

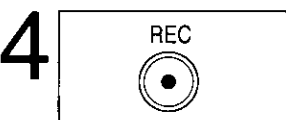

4 Start Recording.

Press REC.

- To edit out unwanted portions, press PAUSE to pause and resume recording.

■ To stop --> Press STOP

■ One Touch Recording

Press REC repeatedly to set the recording length (30 min. ~ 4 hours).

- The VCR turns itself off at a preset time.

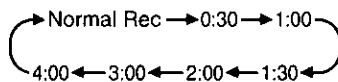

■ Record One Program While Watching Another

Press VCR/TV--> "VCR" disappears on Multi Function Display --> Select Channel at the TV.

■ Selecting Channel at the VCR

Press VCR/TV--> "VCR" appears on Multi Function Display --> Select Channel at the VCR.

You can operate on the VCR

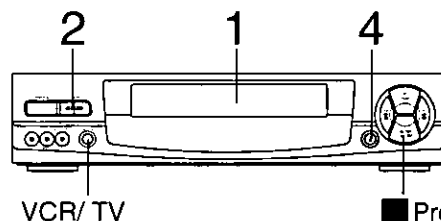

Note

After the VCR has been in Pause mode for 5 minutes, it will stop automatically to protect the tape and the video head.

Advanced Connections

CATV Connection

Make sure to tune TV to VCR output channel the same one you set on back of VCR: CH3 or CH4.

All connections on these pages are made with 75 Ohm coaxial cables.

■ With a Cable Box (Cable Box → VCR)

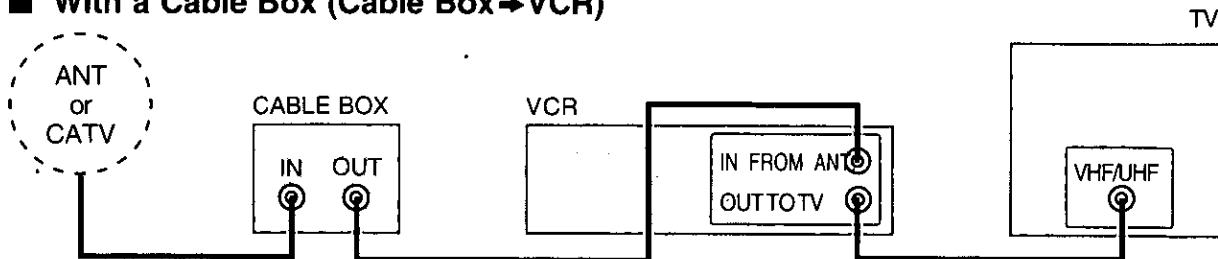

■ With a Cable Box (VCR → Cable Box)

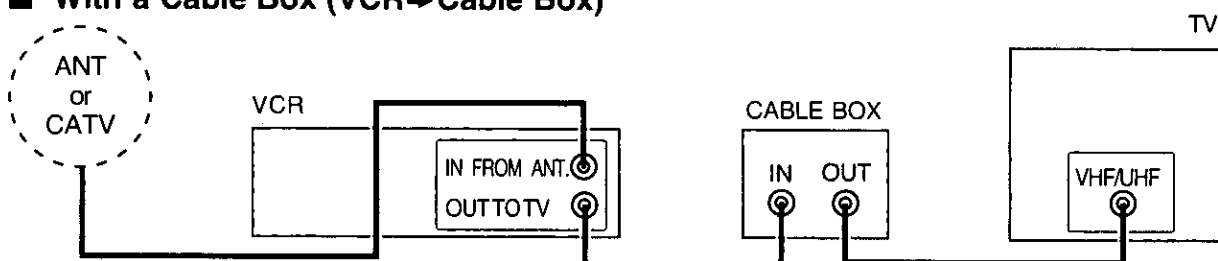

■ With Two Cable Boxes

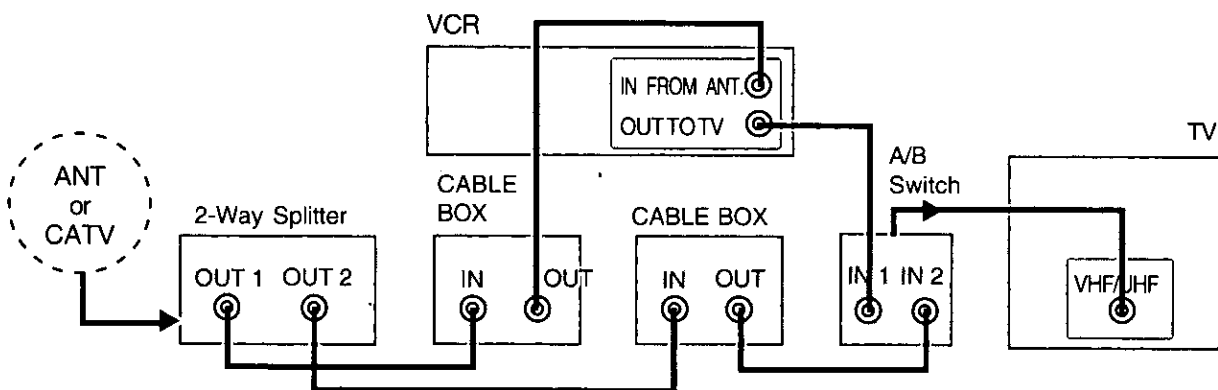

DSS Connection

* DSS® is a registered trademark of DIRECTV, INC., a unit of GM Hughes Electronics.

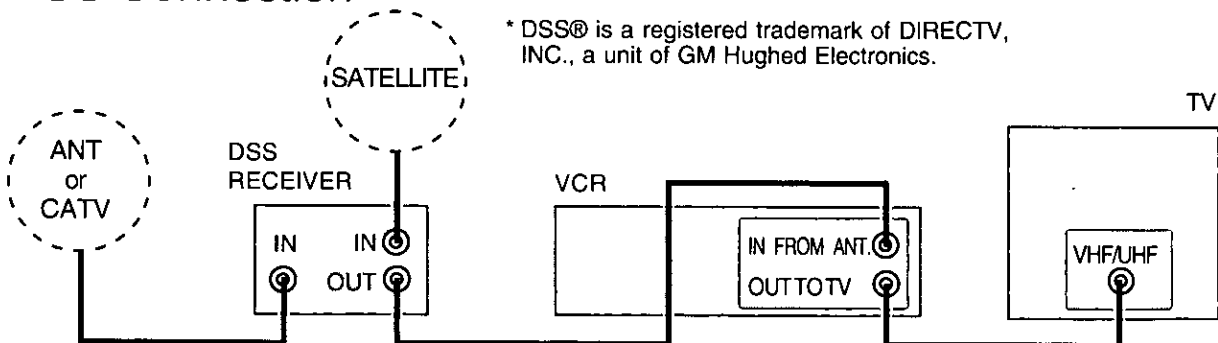

You Can

- record or view any (including scrambled) channel.
- use VCR Remote Control to select channels using Multi-brand control feature.

You Cannot

- view channel other than the one selected for any type of recording.
- do a Timer recording of a channel unless you select it at the cable box.

- view any (including scrambled) channel.
- use VCR Remote Control to select channels without using Multi-brand control feature.

- record scrambled channels.

- record and view both scrambled and unscrambled channels if additional equipment is added. This connection requires: two converter boxes, an A/B switch, and a 2-way splitter.

- view channel other than the one selected for any type of recording.
- do a Timer recording of a channel unless you select it at the cable box.

- record and view any (including scrambled) channel.
- use your VCR Remote Control to select channels using Multi-brand control feature.

NOTE:
DSS receiver must be turned off to view cable box or antenna programs.

- view channel other than the one selected for any type of recording.
- do a Timer recording of a channel unless you select it at the DSS receiver.

Audio/Video Connections

If your TV has AUDIO and VIDEO IN terminals, connect them to VCR for higher quality picture and sound. You can enjoy stereo sound even if your TV is not stereo by connecting a stereo amplifier to the VCR.

VCR

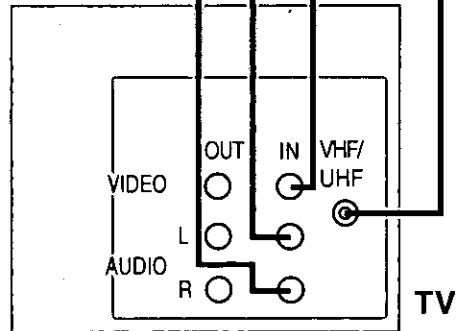
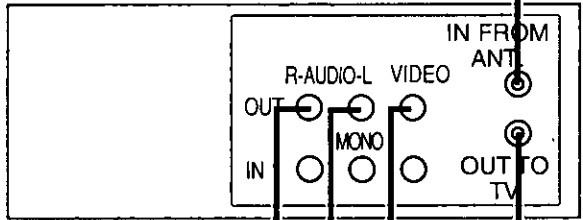

Note

To use your TV as a VCR monitor, set the VIDEO/TV selector on the TV (Monitor/Receiver) to "VIDEO."

Use the L Audio IN jack for proper sound reproduction when connecting to a monaural TV.

Note to CABLE system installer:

This reminder is provided to call the CABLE system installer's attention to Article 820-40 of the NEC in USA (and to the Canadian Electrical Code in Canada) that provides guidelines for proper grounding and, in particular, specifies that the cable ground shall be connected to the grounding system of the building, as close to the point of cable entry as practical.

FCC Warning: Any unauthorized changes or modifications to this equipment would void the user's authority to operate.

This video recorder, equipped with the HQ (High Quality) System, is compatible with existing VHS equipment. Only use those tapes with the **VHS** mark. It is recommended that only cassette tapes that have been tested and inspected for use in 2, 4, 6, and 8 hour VCR machines be used.

Timer Recording

You can set up to 8 programs to be recorded while you are away.

1



Display SET PROGRAM.

Press PROG.*

2

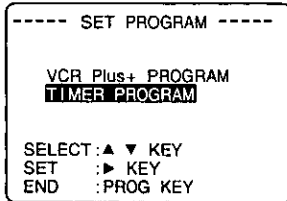

Display Program screen.

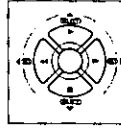

1) Press ▲▼ to select **TIMER PROGRAM**.

2) Press ► to display.

• If a program is already in memory, press ▲▼ and ► to select an unused program number.

• You may not use the VCR buttons on "SET PROGRAM" screen.

3

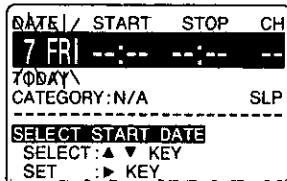

Set the recording DATE.

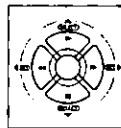

1) Press ▲▼ to select.

2) Press ► or ◀ to set.

• 1-31 = One time
• DAILY = MON~FRI
• WEEKLY = Same time once a week

Example

Today— 7 SELECT▲/▼ Selection Order DAILY

WEEKLY (SAT) WEEKLY (MON) WEEKLY (SUN)

Repeat step 3 to set: start time, stop time, Channel (or LINE for outside source), Category**, tape speed (SP, LP, SLP).

4

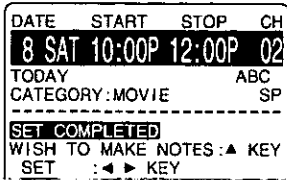

Make the notes.

• If not wanted, go to step 5.

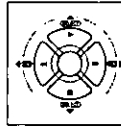

1) Press ▲ to begin.

2) Press ▲▼ to select.

3) Press ► to set.

• Characters will change in the following order.

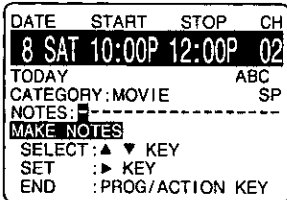
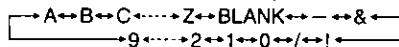

4) Press PROG (or ACTION) to end.

5

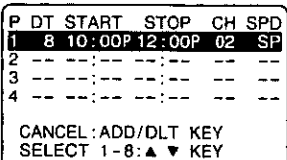

End the program.



Press PROG (or ACTION).

• If start time of programs overlap, these programs will flash.

If you use DSS receiver and enter a channel number of 100-125, select "DSS" or CABLE.

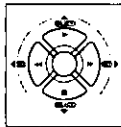
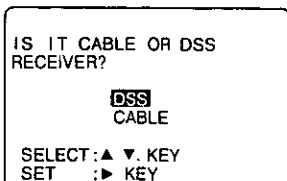

1) Press ▲▼ to select.

2) Press ► to enter.

• The confirmation screen appears above left after this selection.

To Enter More Programs

Press ▲▼ to select, and ► to display a blank program number. Then repeat steps 3 and 4.



Check list before you begin.

- All connections are made. (See pages 4-5.)
- TV and VCR are plugged in and turned on.
- VCR/TV selector is set to "VCR."
- Clock is set to correct time.
- Record tab in place. (See page 42.)
- Remote in VCR mode.

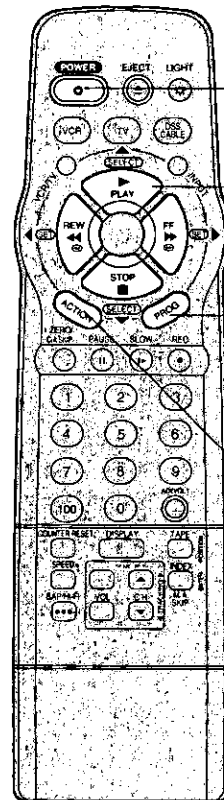

- 7 POWER
- 2 SELECT/SET
- ▲:PLAY
- ▼:STOP
- 5 ◀:REW
- ▶:FF
- 1 PROG
- 4 ACTION
- 5 6
- 4 5 6

** Category Items
N/A(not applicable), SPORTS, MOVIE, COMEDY, MUSIC, DRAMA

Using ▲▼◀▶ keys

You can also operate the menu screen using VCR buttons.

If you use VCR buttons, press CH▲ and CH▼ together to display the menu screen.



- ▲: PLAY
- ▼: STOP
- ◀: REW
- ▶: FF

When menu screens are displayed, PLAY, STOP, REWIND, and FF buttons function as ▲▼◀▶ only.

*Important: If the remote control POWER, ACTION, CH▲/▼, INDEX/M/A SKIP, NUMBERED keys, INPUT, TAPE POSITION, or ADD/HLT button does not work when pressed, press the VCR button on the remote and try the button again.

6



Exit program mode.
Press PROG (or ACTION).

7

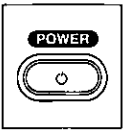

Set timer.
Press POWER OFF.

- When recording programs via a cable box, make sure the cable box is left ON and tuned to the desired channel.



Multi Function Display

To cancel Timer Recording (Recording is in progress)

Press POWER and then STOP within 10 seconds to cancel the Timer recording. ("TIMER" goes out on Multi Function Display.)

To review program contents on the VCR

Recording is not in progress

Press PROG in Power Off mode. Every time that button is pressed, the program contents are indicated in turn on the Multi Function Display.

Recording is in progress

Press PROG. The program content which advances at present is indicated on the Multi Function Display.

You can also display Program screen from Menu

- 1) Press ACTION to display Menu.
• You can also set up using VCR buttons. See the bottom right of the page 16.
- 2) Press ▲▼ and ► to select and set SET UP FEATURE.
- 3) Press ▲▼ to select TIMER PROGRAM and press ► to display Program screen.
- 4) Go to step 3 on the page 16.

Important notes when using a DSS receiver

- When recording programs via a DSS receiver, the DSS receiver must be left on.
- When recording programs via an antenna or cable, the DSS receiver must be turned off.

Review, Replace or Clear Program Contents:
(Recording is not in progress)

- a Repeat steps 1~2 on page 16.**
• If necessary, press POWER ON.

b

P	DT	START	STOP	CH	SPD
1	DAY	9:00A	12:00A	08	SP
2	8	10:00P	12:00P	02	SP
3	10	8:00P	9:00P	10	SP
4	SU	9:00P	10:00P	L1	LP

CANCEL: ADD/DLT KEY
SELECT 1-8: ▲ ▼ KEY

Select program.

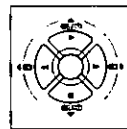

- 1) Press ▲▼ to select number.

c

To Replace program...

DATE	START	STOP	CH
8 SAT	10:00P	12:00P	02

TODAY: ABC SP
CATEGORY: MOVIE
NOTES: STAND BY ME
SELECT START DATE
SELECT: ▲ ▼ KEY
SET: ◀ ▶ KEY

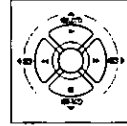

- 1) Press ► to display.
- 2) Press ▲▼◀▶ to set new program contents.

To Clear program...

P	DT	START	STOP	CH	SPD
1	--	--	--	--	--
2	8	10:00P	12:00P	02	SP
3	10	8:00P	9:00P	10	SP
4	SU	9:00P	10:00P	L1	LP

SELECT 1-8: ▲ ▼ KEY
ENTER: ▶ KEY

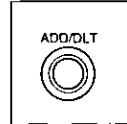

- 1) Press ADD/HLT.

d



End the program.

- 1) Press PROG (or ACTION).
- If there are programs, press POWER OFF.

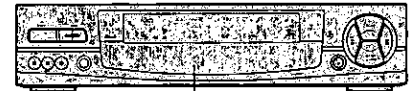

Multi Function Display

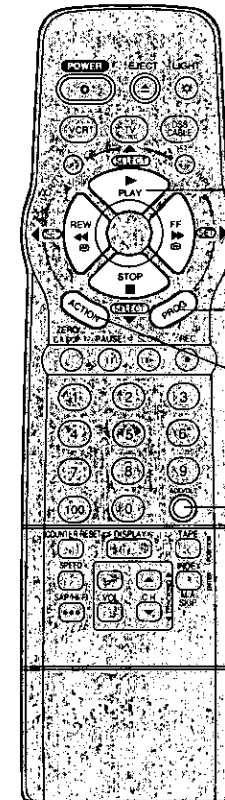

b SELECT/SET

- ▲: PLAY
- ▼: STOP
- ◀: REW
- ▶: FF

d PROG

d ACTION

C ADD/DELETE

Timer Recording

Timer Recording Using VCR Plus+ System

Auto VCR Plus+ System Channel Setup (Part 1)

In order for VCR to read VCR Plus+ code, some set up is required. Guide (VCR Plus+) channel number is assigned to each local broadcast and cable station. Because this number sometimes differs from channel TV receives station on, it is necessary to program the VCR with local channel information. To receive VCR Plus+ channels automatically, perform the steps below. Or, see "Manual VCR Plus+ System Channel Setup" section on page 20.

1  **Display menu.**
Press ACTION.*

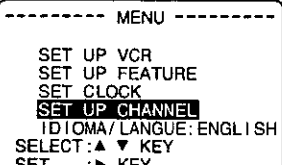
2  **Display SET UP CHANNEL.**
1) Press ▲▼ to select.
2) Press ► to display.

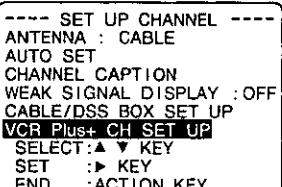
3  **Display VCR Plus+ CH SET UP.**
1) Press ▲▼ to select.
2) Press ► to display.

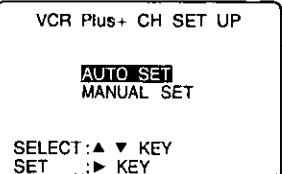
4  **Select AUTO SET.**
1) Press ▲▼ to select.
2) Press ► to set.

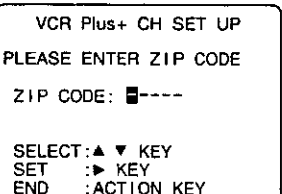
5  **Enter Zip Code.**
1) Press ▲▼◀▶ to select and enter each number.
2) Press ► or ACTION to set.

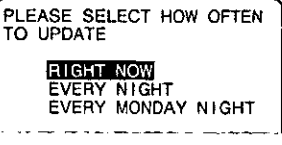
6  **Select When to Update.**
1) Press ▲▼ to select.
2) Press ► to set.

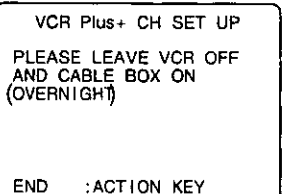
7  **End setup.**
Press ACTION.
* Make sure to leave VCR off (overnight.) If controllable, leave your cable box on.

VCR Plus+ System is ... a feature that allows you to set most items of a timer recording by simply entering a special code number (PlusCode programming number) found in TV GUIDE and selected newspaper TV listings.

Process of Recording



Important Note

- "One Time VCR Setup" on pages 6-11 must be completed before "Auto VCR Plus+ System Channel Setup" can be done. If any part of setup is incomplete, a warning screen appears.
- If your VCR connection type changes from type A to B, on page 6, perform "To Setup VCR in Case a Cable Box or DSS Receiver was Installed or Replaced" section on page 10 before proceeding with these steps.
- Complete this page only if type B connection (see page 6.) is used.

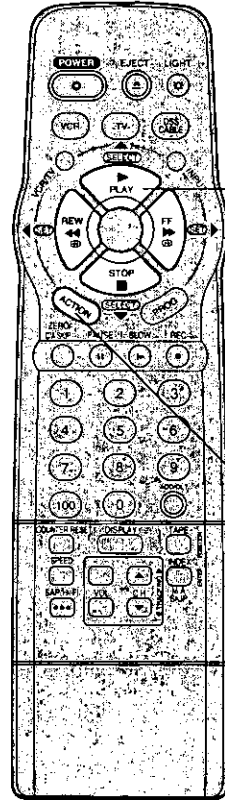

- 2 SELECT/SET
3 ▲:PLAY
4 ▼:STOP
5 ▲:REW
6 ▼:FF
1 ACTION
5
7

Notes

- Make each entry within 5 minutes or VCR will leave this mode.
- Once local channels have been programmed, they will stay in memory, even in the case of a power failure.
- "ALL SET" will flash on Multi Function Display during Auto VCR Plus+ System Setup.
- If the start time for a timer recording comes up during Auto VCR Plus+ System Setup, the timer recording will have priority.

Important: If the remote control POWER, ACTION, PROG, CH▲/▼, INDEX/PAUSE, or ADD/DELETE button does not work when pressed, press the VCR button on the remote and try the button again.

Auto VCR Plus+ System Channel Setup (Part 2)

Before you perform the following steps, you should have:

- completed "Auto VCR Plus+ System Channel Setup (Part 1)" on page 18.
- left VCR off overnight, and turned it back on after 9:00 AM the next day.

1 If channel updating was successful...

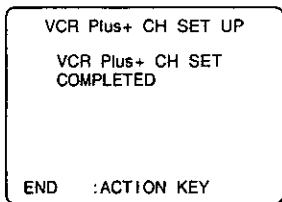

Exit this mode.



Press ACTION.

If VCR could not distinguish channel map...

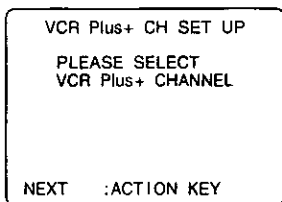

Display SELECT VCR Plus+ CH.



- 1) Press ACTION to display.
- 2) Continue with step 2.

2

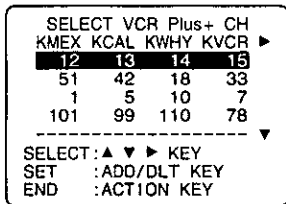

Select channel map for your area.

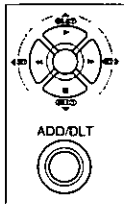

- 1) Press ▲▼ ◀▶ to select.
- 2) Press ADD/ DLT to set.

3

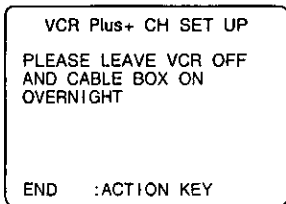

End Setup.

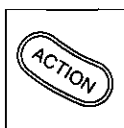

Press ACTION.

- Make sure to leave VCR off overnight. If controllable, leave your cable box on.

Channel map will be updated overnight. If it was successful, "VCR Plus+ CH SET COMPLETED" appears on screen. And then, press ACTION to exit.

Repeat these steps as necessary.

If Auto Setup fails, do "Manual VCR Plus+ System Channel Setup" on page 18.

Process of Recording

Setup → Programming

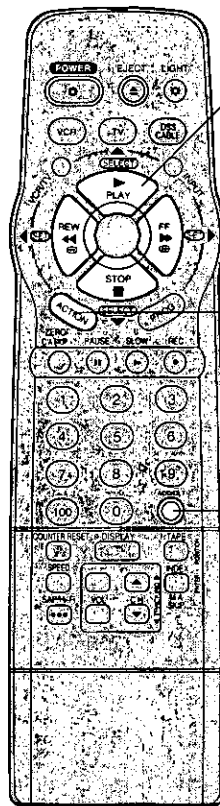

2 SELECT/ SET
▲ :PLAY
▼ :STOP
◀ :REW
▶ :FF

1 ACTION
3

2 ADD/ DELETE

Timer Recording Using VCR Plus+ System

To Change or Update Auto VCR Plus+ System Channel Setup

(E.g. you selected wrong channel map or zip code.)

a Do "Auto VCR Plus+ System Channel Setup (Part 1)" steps 1-4 on page 18.

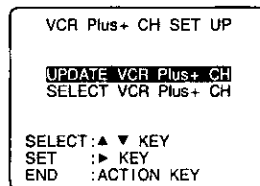

b Press ▲▼ to select UPDATE VCR Plus+ or SELECT VCR Plus+ CH, then press ►.

c If you selected UPDATE VCR Plus+ CH, perform steps 5-7 in the "Auto VCR Plus+ System Channel Setup (Part 1)" section on page 18.

If you selected SELECT VCR Plus+ CH, perform steps 2-3 in the "Auto VCR Plus+ System Channel Setup (Part 2)" section on this page.

Manual VCR Plus+ System Channel Setup

- Before you begin, complete "Channel Setup Preparations" below right.

Important Note

- If your VCR connection type changes from type A to B, on page 6, perform "To Setup VCR in Case a Cable Box or DSS Receiver was Installed or Replaced" section on page 10 before proceeding with these steps.

1 Do "Auto VCR Plus+ System Channel Setup (Part 1)," steps 1~3 on page 18.

2

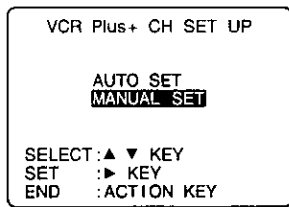

Select MANUAL SET.

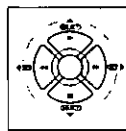

- 1) Press ▲▼ to select.
- 2) Press ► to set.

IMPORTANT NOTE:

For step 3, use the list you prepared. You may leave lines blank if you do not receive that station, or if the GUIDE CH number and the CABLE (or TV) CH numbers are the same.

3

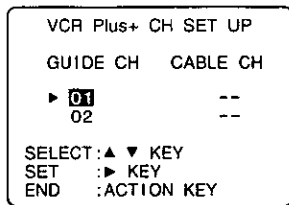

Select VCR Plus+ channels.

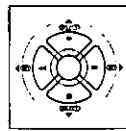

- 1) Press ► to move cursor to right column.

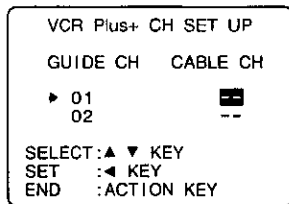

- 2) Press ▲▼ to change CABLE (or TV) CH number.
- 3) Press ◀ to set.
- 4) Press ▲▼ to scroll up/down GUIDE CH column.

- Repeat step 3 until list is complete.

To make corrections,

Press ▲▼ and ► to move to error, then ▲▼ to change, or ADD/DEL* to erase number.

4

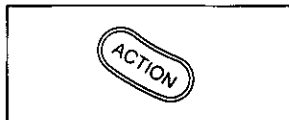

End setup.

Press ACTION three times.

Process of Recording

Setup → Programming

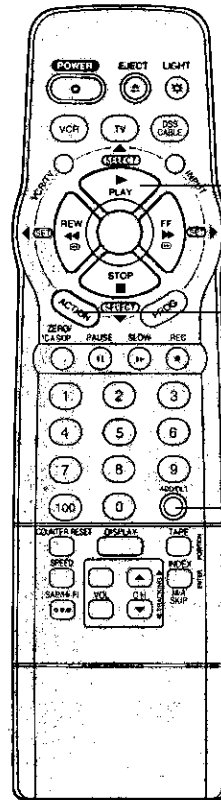

- 2 SELECT/SET
- 3 ▲:PLAY
▼:STOP
◀:REW
▶:FF
- 4 ACTION
- 3 ADD/DELETE

Channel Setup Preparations

In order to complete step 3 left, make a local channel list (see example below).

You will need the following:

- A line up of normal TV and/ or Cable stations and the channel number you receive them on.
- A list of Guide (VCR Plus+) channel numbers for the stations you receive found in TV Guide and selected newspapers.

- 1 Make a 3-column chart. In the left column, write the name of all the stations you receive.
- 2 In the middle column, write each station's Guide (VCR Plus+) number from TV Guide.
- 3 In the right column, write the channel number your TV receives the station on.

EXAMPLE ONLY

Broadcast or Cable Station Name	Assigned Guide (VCR Plus+) channel no.	Channel no. your TV receives the station on
HBO	33	15
Nickelodeon	38	20
CBS	04	04
FOX	11	

Notes

- Make each entry within 5 minutes or the VCR will leave this mode.
- Once local channels have been programmed, they will stay in memory, even in the case of a power failure.

VCR Plus+, C³, ALL SET, and PlusCode are registered trademarks of Gemstar Development Corporation. The VCR Plus+ system is manufactured under license from Gemstar Development Corporation.

Important: If the POWER, ACTION, PROG, CH▲/▼, INDEX/ M/A SKIP, DSS/CABLE BOX, INPUT, TAPE POSITION, or ADD/DLT button does not work when pressed, press the VCR button on the remote and try the button again.

Check list before you begin.

- The clock is set.
- VCR Plus+ System Setup is complete (see pages 18-20).

1  **Display SET PROGRAM.**
Press PROG.

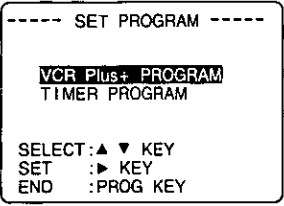
2  **Display VCR Plus+ screen.**

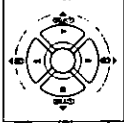
 1) Press ▲▼ to select.
2) Press ► to display.

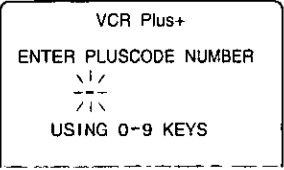
3  **Enter PlusCode programming number.**

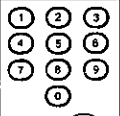
 1) Press Numbered keys.
2) Press PROG to lock in the program.

To make corrections, press ◀ repeatedly to delete the PlusCode programming number.

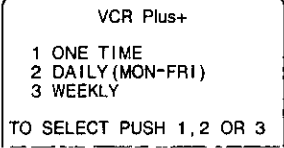
 **Enter record frequency.**

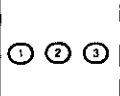
 3) Press 1, 2, or 3 key to select program type.

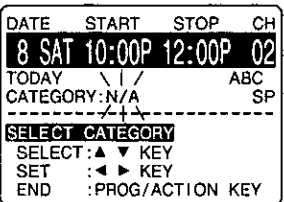
4  **Select Category.****

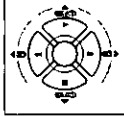
 1) Press ▲▼ to change.
2) Press ► set.

Change record speed. Repeat 1) and 2).

5 Make notes. -----> Do step 4 on page 16.
• If not wanted, go to step 6.

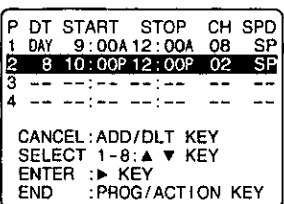
6  **End programming.**

 1) Press PROG (or ACTION).
To cancel, press ADD/DLT.
2) Press PROG (or ACTION) again to exit.

CANCEL: ADD/DLT KEY
SELECT 1-8: ▲ ▼ KEY
ENTER: ► KEY
END: :PROG/ACTION KEY

• If start time of programs overlap, these programs will flash.

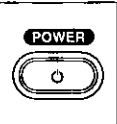
7  **Set timer.**
Press POWER OFF.

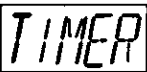
 **TIMER**
Multi Function Display

Process of Recording

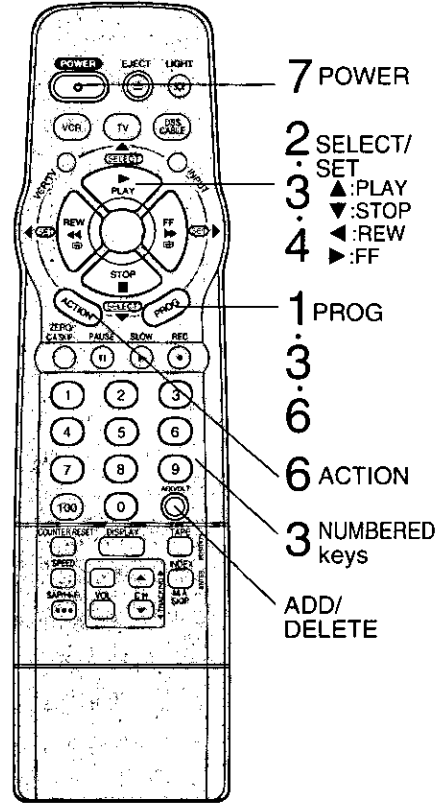

Timer Recording Using VCR Plus+ System

** Category Items
N/A(not applicable), SPORTS, MOVIE, COMEDY, MUSIC, DRAMA

- Use normal Timer Recording steps if:**
- the PlusCode programming number for a program is not listed.
 - you anticipate the program, such as a sporting event, to run over the scheduled stop time.

- See page 17 to:**
- cancel a timer recording in progress.
 - replace program contents.
 - review or clear program contents once set.

- Important notes for DSS/Cable Box users**
- When recording via DSS, the receiver, must be left on.
 - When recording via cable or antenna, DSS receiver must be off.

- Notes**
- Avoid overlapping program times.
 - VCR PlusCode programming numbers can not be used to program the VCR to record DSS channels.
 - You can obtain unlisted PlusCode numbers by calling 1 - 900 - 454 - 7587. Call costs approximately \$.95 per minute.

Multi-Brand Control Feature

The Remote Control may be set up to control some TV or Cable/DSS Box functions.

Multi-Brand Control Setup

1 Find your TV, Cable or DSS Receiver Brand Code Number on following page.

2 Setup for TV

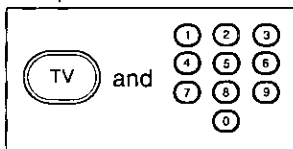

Setup remote.

Hold down TV and enter code with NUMBERED keys.

Setup for Cable or DSS

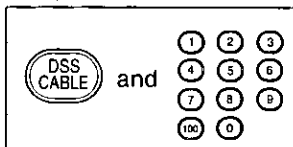

Hold down DSS/CABLE and enter code with NUMBERED keys.

- For code 100 or greater, press the 100 key first, then remaining digit. e.g. for 102, press 100, then press 0, and then press 2.

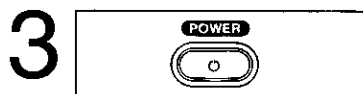

Confirm code entry.

Press POWER to turn selected unit ON or OFF.

- See table below for list of controllable functions in each mode.

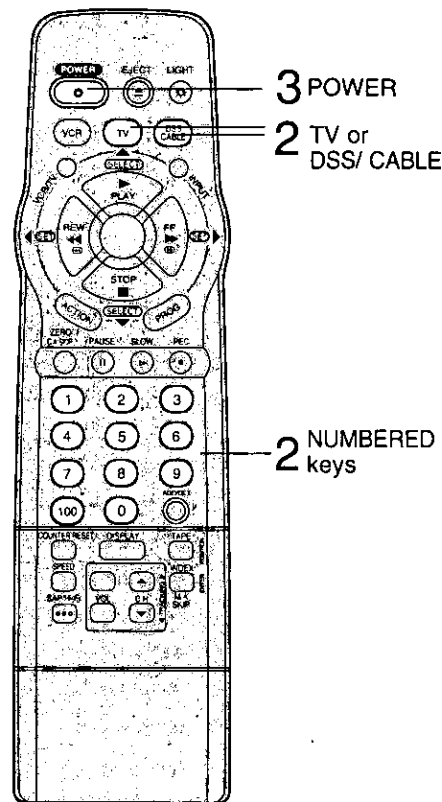

Notes

- Please repeat Multi-Brand Control setup after replacing remote control batteries.
- The remote control will not operate all TVs, Cable Boxes, and DSS receivers made by manufacturers listed. If you get no results, your particular brand cannot be controlled.

Using the Multi-Brand Control

After remote control is setup, you can select VCR, TV, or DSS/CABLE for the desired function.

Press VCR or TV or DSS/CABLE on the remote control.

This table shows which buttons are available for each mode.

Mode \ Available Buttons	VCR	TV	CABLE/ DSS
VCR	All Functions	VOL UP/DOWN	---
TV	VCR/TV, PLAY, STOP EJECT, SAP/ Hi-Fi, DISPLAY, FF, REW, PAUSE, SLOW, REC, SPEED, ZERO/ C/A SKIP, COUNTER RESET	POWER, INPUT, NUMBERED keys, ENTER, CH UP/ DOWN, VOL UP/DOWN	---
CABLE/ DSS	VCR/TV, PLAY, STOP EJECT, SAP/ Hi-Fi, DISPLAY, FF, REW, PAUSE, SLOW, REC, SPEED, ZERO/ C/A SKIP, COUNTER RESET	VOL UP/ DOWN	POWER, ENTER, NUMBERED keys (except 100key), CH UP/ DOWN

Note In TV or DSS/ CABLE mode, it may be necessary to press ENTER after pressing NUMBERED keys for channel selection.

TV Brand Code Numbers

Panasonic	01, 02	Sylvania	05	JVC	11
Quasar	01, 02	Sharp	06, 07	Hitachi	12
RCA	03	Sony	08	Mitsubishi	07, 13
GE	03	Toshiba	09	Samsung	14
Zenith	04	Sanyo	10	Gold Star	15, 16, 17
Magnavox	05	Fisher	10		

Cable Box Brand Code Numbers

Archer	01, 05, 06, 44, 63, 91, 126	Quest	05, 06
Cabletenna	01, 44, 63, 91, 126	Radio Shack	44, 51, 59, 75
Cableview	04, 30, 42, 44, 52, 63, 124, 126	RCA	16, 17, 97, 109
Century	44, 51, 59, 75	Realistic	44, 51, 59, 75, 126
Citizen	04, 30, 42, 44, 52, 63, 124, 126	Recoton	44, 51, 59, 75, 126
Curtis	08, 09, 53, 61, 87	Regal	14, 15, 28, 41, 102, 103, 104, 108, 130
Diamond	01, 44, 63, 91, 126	Regency	28, 130
Drake	67	Rembran	01, 32, 39, 42, 44, 63, 126
Eagle	13, 20, 22, 26, 40, 58, 62, 107	Salora	68
Eastern	28, 130	Samsung	05, 06, 32, 40, 42
GC Brand	04, 30, 42, 44, 52, 63, 124, 126	Scientific Atlanta	08, 09, 53, 61, 87
Gemini	04, 124	Sheritech	27
General Electric	01, 57	Signal	26, 112
General Instruments	01, 02, 03, 04, 34, 55, 65, 67, 68, 83, 91, 115, 117, 118, 124	SL Marx	06; 32, 40, 42, 43, 44, 52, 63, 126
Hamlin	14, 15, 28, 41, 102, 103, 104, 108, 130	Spucer	16, 17, 97, 109
Hitachi	31	Standard Components	32, 39, 42, 44, 126
Jasco	04, 124	Stargate	04, 06, 30, 32, 40, 42, 44, 52, 63, 124, 126
Jerrold	01, 02, 03, 04, 34, 55, 65, 67, 68, 83, 91, 115, 117, 118, 124	Sylvania	19
Macom	31	Teknika	74
Magnavox	26, 112	Telecaption	77, 127
Matsushita	16, 17, 97, 109	Televue	06, 32, 40, 42
Movietime	32, 38, 39, 40, 42, 44, 126	Texscan	18, 19
NEC	32, 38, 40	Tocom	01, 33, 34, 42, 66, 91
NOVAVISION	08, 09, 53, 61	Toshiba	36
NSC	32, 38, 40	Uniden Satellite	65
Oak	11, 46, 129	Unika	01, 44, 63, 91, 126
Oak Sigma	11, 46, 129	Universal	42, 43, 44, 52, 63, 126
Panasonic	16, 17, 97, 109	Videoway	07, 23, 50, 129
Philips	07, 13, 20, 23, 24, 50, 128, 129	Vid Tech	64
Pioneer	05, 06	Vidter	64
Pulsar	04, 30, 42, 44, 52, 63, 124, 126	Viewstar	13, 20, 22, 26, 40, 58, 62, 107
		Zenith	07, 23, 50, 129

DSS Brand Code Number

Toshiba	92	Panasonic	96
Hitachi/ Hughes	93	RCA	97
Magnavox/ Uniden 1	94	Sony	98, 105
Magnavox/ Uniden 2	95		

Important Notes

- Due to changes in infra-red commands used by manufacturers, some brands have several codes. If your unit does not respond to the first code, please try the next one.
- Some TV, Cable Box and DSS Receiver brands require you to turn on the power manually.
- Not all functions listed may be controlled by this remote control.

Tape Operation

COMMERCIAL ▶▶ ADVANCE®

COMMERCIAL ▶▶ ADVANCE® detects and marks the beginning and end points of commercials on your tape for recordings over 15 minutes in length. When COMMERCIAL ▶▶ ADVANCE® marked tape is played back, the VCR automatically advances through the commercial segments at high speed. You can also set this feature to Manual so as to have more control over the advance process. The effectiveness of this system can vary due to differences in the way television stations broadcast. See page 26 for answers to the most commonly asked questions about this feature.

Check list before you begin.

- All connections are made.
- One time Setup completed.
- VCR is plugged in.
- TV is turned on and set to the VCR channel (CH 3 or 4).

COMMERCIAL ▶▶ ADVANCE® Marking

When C/A RECORD: ON, VCR automatically rewinds the tape after a recording has been made and marks the beginning and end of any detected commercial blocks. After marking is done, the tape is returned to the end of recording. Commercials are not erased from the tape.

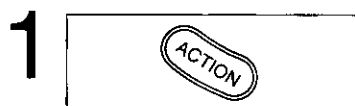

Display menu.
Press ACTION.*

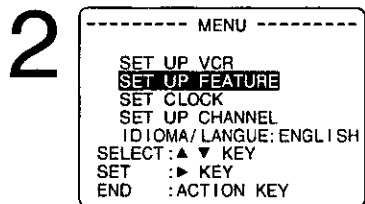

Display SET UP FEATURE.

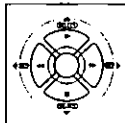

- 1) Press ▲▼ to select.
- 2) Press ► to display.

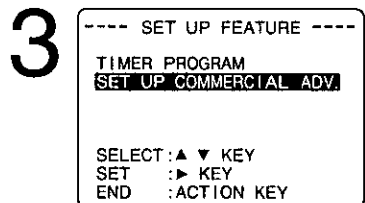

Display SET UP COMMERCIAL ADV.

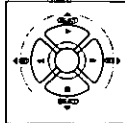

- 1) Press ▲▼ to select.
- 2) Press ► to display.

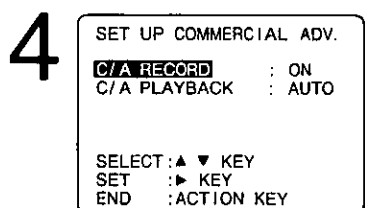

Set ON or OFF.

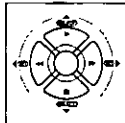

- 1) Press ▲▼ to select.
- 2) Press ► to set.

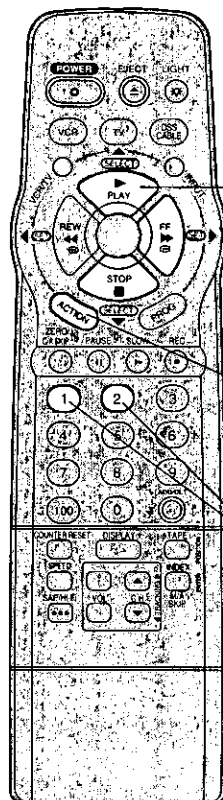

- 2 SELECT/SET
- 3 ▲:PLAY
- 4 ▼:STOP
- ▶:FF

- 1 ACTION
- 5

NUMBERED keys

Note

- When using the timer to record two adjacent shows on the same channel, better accuracy can be obtained by programming each shows separately.

ON Timer, VCR Plus+ System, and One Touch recordings are marked automatically.

THE VCR IS WAITING TO MARK COMMERCIALS IN THE PROGRAM YOU RECORDED.

MARKING
NOW : PUSH 1 KEY
LATER : PUSH 2 KEY
CANCEL : PUSH ACTION KEY

When STOP is pressed during normal recording, Select One of a) or b) or c).

- a) Press 1 key to mark the recording now.
"NOW MARKING COMMERCIALS" appears.
- b) Press 2 key to mark the recording later (after the power has been turned off).
• If the tape is rewound and another recording started before the power is turned off, commercials may not be marked correctly.
- c) Press ACTION to cancel the marking of this recording.

OFF The VCR will not mark commercials.

When you are editing or dubbing a tape, or when you do not wish to use this feature, off should be selected.

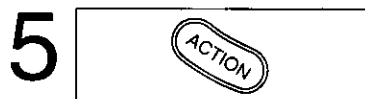

Return to normal screen.
Press ACTION three times.

Important: If the remote control POWER, ACTION, PROG, CH▲/▼, INDEX/ M/A, NUMBERED keys, INPUT, TAPE POSITION, or ADD/HLT button does not work when pressed, press the VCR button on the remote and try the button again.

COMMERCIAL▶▶**ADVANCE**® Playback

When playing back recording which have been marked using **COMMERCIAL▶▶ADVANCE**® feature, you can either set VCR to automatically advance through marked commercial blocks, or set it so that commercials are only skipped on your command.

1 

Display menu.
Press ACTION.*

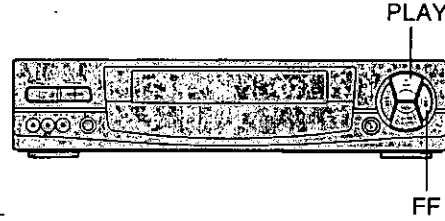

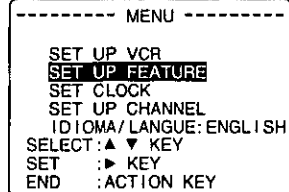
2 

Display SET UP FEATURE.

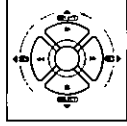

- 1) Press ▲▼ to select.
- 2) Press ▶ to set.

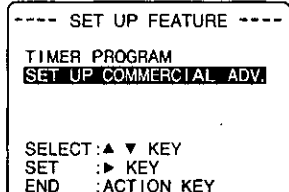
3 

Display SET UP COMMERCIAL ADV.

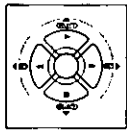

- 1) Press ▲▼ to select.
- 2) Press ▶ to set.

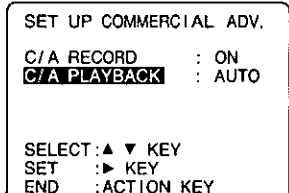
4 

Set AUTO or MANUAL.

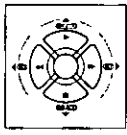

- 1) Press ▲▼ to select.
- 2) Press ▶ to set.

AUTO VCR will automatically advance through marked commercial blocks recorded on the tape and then resume playback.

MANUAL VCR will advance through commercials only when ZERO/ C/A SKIP is pressed. Playback will resume when the end mark of a commercial block is found, or a new recording or blank portion is detected, or after 8 minutes.

5 

Return to normal screen.
Press ACTION three times.

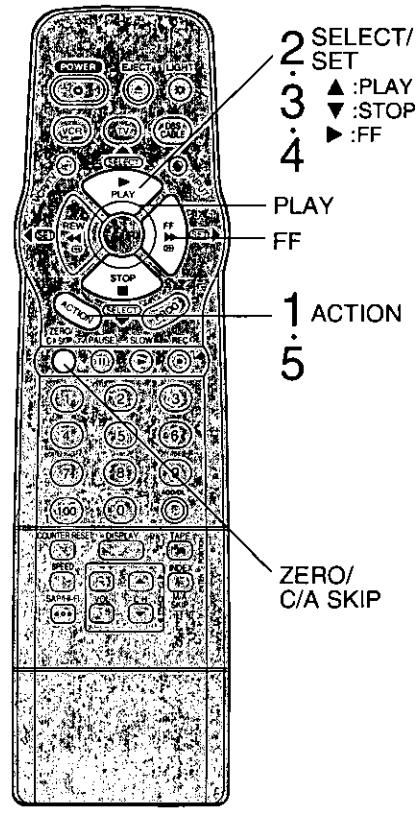

Tape Operation

COMMERCIAL▶▶ADVANCE® is a trademark of SRT, Inc. A Jerry Iggulden invention licensed in association with Arthur D. Little Enterprises, Inc. U.S.Pat. No. 5,333,091 other patents pending

- Notes**
- The selection mode in step 4 remains set unless there is a power outage in which case the original factory setting will be restored.
 - If playback is started in the middle of a commercial, only a single commercial is shown, or an individual commercial is longer than 1 minute, a commercial may not be skipped. Press FF to quickly advance through the commercial.
 - Part of a recorded program may be skipped over if the program portion between commercials is less than one minute or there are frequent dark and quiet scenes during the program. To view the portion of tape being incorrectly skipped, press PLAY while the VCR is skipping, reverse the tape to a point just prior to where the skipping began and press PLAY again. This time the group will not be automatically skipped. Automatic skipping will be re-enabled when the end of the marked group is detected.

Tape Operation (continued)

The most commonly asked questions about **COMMERCIAL**ADVANCE*** are answered below.

Question	Answer
How fast does the VCR advance through commercials?	The VCR advances through a 3-minute commercial block in about 8 to 12 seconds if the tape speed is SLP. In SP, it takes about 25 to 35 seconds.
Are commercials advanced through only when I playback a recording?	Yes. The commercials are not marked until after the recording is finished.
Are commercials still recorded on the tape in case I choose to view them sometime?	Yes. By setting the C/A PLAYBACK to MANUAL, see page 25, you can view or advance through commercials as desired.
Does COMMERCIAL**ADVANCE* work in all recording speeds?	Yes. COMMERCIAL**ADVANCE* works in SP, LP, and SLP.
Does the VCR advance through commercials each time I playback tapes which were recorded using COMMERCIAL**ADVANCE* ?	Yes. As long as C/A PLAYBACK is set to AUTO, see page 25, the VCR should advance through commercials each time the tape is played back.
After marking commercials, does the VCR stop at the end of the tape, or rewind to the beginning?	The tape stops at the end of the recording so that any additional timer recordings can be performed.
Can I play my COMMERCIAL**ADVANCE* recordings in non- COMMERCIAL**ADVANCE* VCRs?	Yes. COMMERCIAL**ADVANCE* marked recordings will play in non- COMMERCIAL**ADVANCE* VCRs, but commercials will not be advanced through.
Does the marking process interfere with other programmed recordings?	No. If the interval between 2 or more timer programs is not sufficient to mark the recording, marking will be done after all recordings are complete and the power goes off.
What happens if I cancel the marking in progress so I can use the VCR?	Marking will be resumed when the VCR's power is turned off as long as the tape has not been ejected.
What if part of my program is advanced through along with the commercials?	Please see the 3rd note on page 25.
<p>Additional Notes:</p> <ul style="list-style-type: none"> • Because of the various ways in which commercials are broadcast, the VCR may not be able to recognize all commercials. • If a timer recording is scheduled for the middle of the night, please be aware that the VCR will make some noise as it rewinds and fast forwards the tape while marking commercials. 	

COMMERCIALADVANCE*** is a trademark of SRT, Inc.

A Jerry Iggulden invention licensed in association with Arthur D. Little Enterprises, Inc.

U.S.Pat. No. 5,333,091
other patents pending

Important: If the **STOP**, **ACTION**, **PROG.**, **CH▲/▼**, **INDEX/M/A SKIP**, **TAPE POSITION**, or **ADD/HLT** button does not work when pressed, press the **VCR** button on the remote and try the button again.

MOVIE**ADVANCE™

MOVIEADVANCE™** helps you locate certain parts of prerecorded movies (rented or purchased). The feature works in two ways.

- You can go to the beginning of the movie.
- You can skip from one preview to the next.

MOVIEADVANCE™** works only on cassette recorded in SP speed with the record tab removed.

1  **Insert a cassette without record tab.**

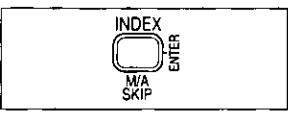
2  **Display "SELECT SEARCH MODE."**
1) Press INDEX/ M/A SKIP.*

• If you inserted a cassette with the record tab or if you selected "INDEX SEARCH" go to page 28.

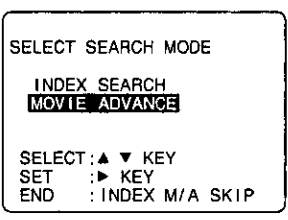
3  **Display MOVIE ADVANCE.**
1) Press ▲▼ to select.
2) Press ► to set.

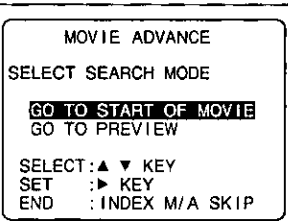
4  **Select GO TO START OF MOVIE or GO TO PREVIEW.**
Press ▲▼ to select.

Select "GO TO START OF MOVIE," if you want to advance directly to beginning of the movie.
--> continue with step 5.
Select "GO TO PREVIEW," if you want to view the first (next) preview.
--> go to "To Search for Preview" at right.

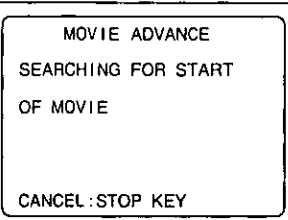
5  **Start searching.**
Press ►.
• To cancel, press STOP.

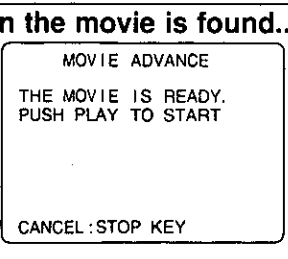
6  **When the movie is found...**
Start playback.
Press PLAY.
• To cancel, press STOP.
• The display will time out after 3 minutes and the VCR will enter the Stop mode.

- Check list before you begin.
- All connections are made.
 - One time Setup completed.
 - VCR is plugged in.
 - TV is turned on and set to the VCR channel (CH 3 or 4).

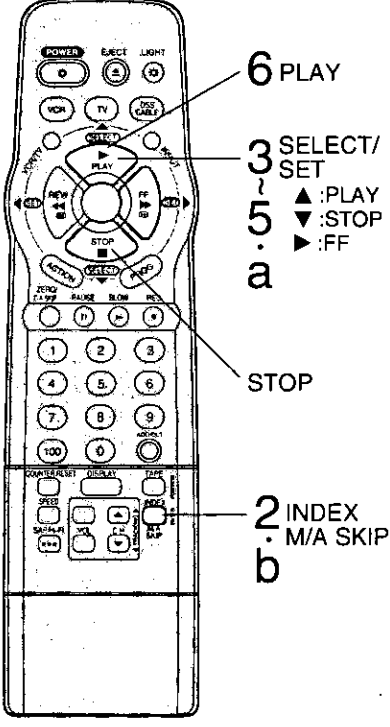

To Search for Preview.

You can override the operation of **MOVIE**ADVANCE™** SEARCH FOR PREVIEWS mode by pressing MA SKIP during tape searching. **MOVIE**ADVANCE™** works by searching the tape past each preview and then reversing back to the start of the detected preview. While the tape is reversing back, if INDEX/ M/A SKIP is pressed, **MOVIE**ADVANCE™** will begin searching for the next preview. While searching for the next preview, if you see the start of a preview which you wish to watch, press MA SKIP and **MOVIE**ADVANCE™** will immediately reverse back to the start of that preview, instead of searching further past the preview start point. Once the VCR is playing a preview, press MA SKIP to advance to the next preview, long commercial or the start of the movie (whichever is next).

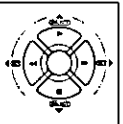
a  **Start preview searching.**
1) In step 4 at left, select Go To PREVIEW.
2) Press ►.
• If you want to playback, press PLAY.

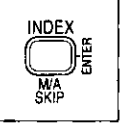
b  **When a preview is detected, VCR will start playback.**
Start next preview searching.
Press INDEX/ M/A SKIP.
• To cancel, press STOP.

Tape Operation

VHS Index Search System

Each time recording is made, an invisible index mark is placed on the tape. When timer recordings are made, program index and information are also included. These index marks can be used to access or scan recordings.

Direct Access (For normal and /or timer recordings)

Go directly to desired recording.

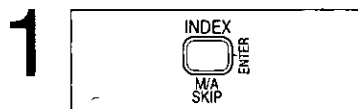

Display SELECT SEARCH MODE.

Press INDEX/ M/A SKIP.*

- * If there are no timer recordings on the Program Index List, go to step 3.

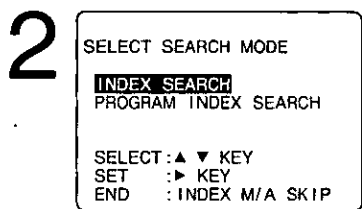

Display INDEX.

- 1) Press ▲▼ to select.
- 2) Press ► to display.

- This screen appears only if there are timer recordings.



Select the recording number.

Press NUMBERED keys.

- To calculate number, see below.

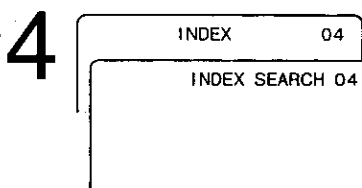

Start search.

Press FF or REW.

- When search is finished, playback begins.

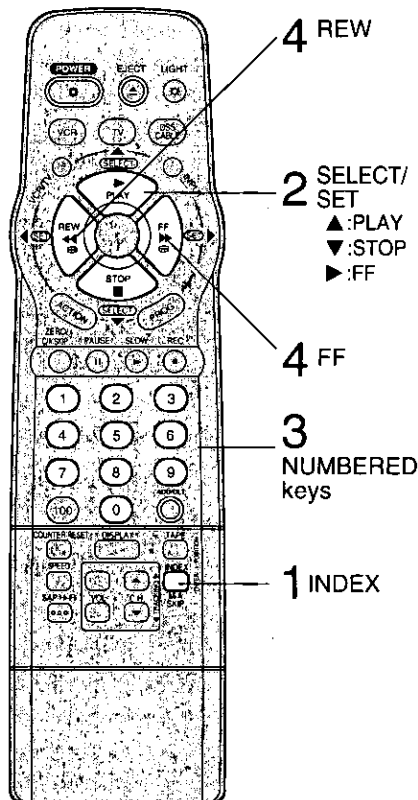

■ To Calculate Index Number

Example 1:

If you are watching recording 4 and you want to watch recording 2, enter 3 in step "3" and press REW.

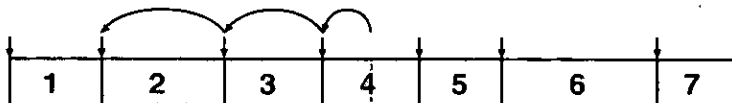

Example 2:

If you are watching recording 2 and you want to watch recording 6, enter 4 in step "3" and press FF.

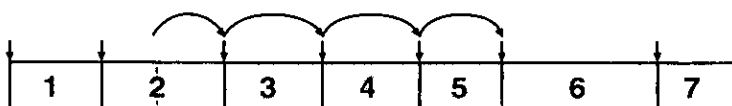

NOTE: ↓ indicates start points of each recording.

Notes

- Make each entry within 10 seconds, or the Index Search mode will be canceled.
- If Direct Access or Index Scan is started very close to an index mark, that index mark may not be counted in the search.

Important: If the remote control buttons, ACTION, CH▲/▼, INDEX/M/A SKIP, NUMBERED KEYS, INPUT, TAPE POSITION, or ADD/DLT button does not work when pressed, press the VCR button on the remote and try the button again.

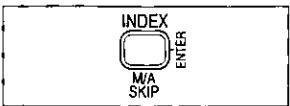
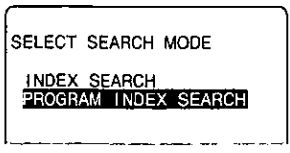
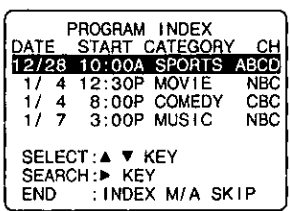

Program Index Search (For timer recordings only)

Choose a timer recorded program from a Program Index List. When the tape is ejected or normal recording is started, all program index data is deleted.

- 1**  **Display SELECT SEARCH MODE.**
Press INDEX/ M/A SKIP.
- 2**  **Display PROGRAM INDEX.**
1) Press ▲▼ to select.
2) Press ► to display.
- 3**  **Select the desired recorded program.**
1) Press ▲▼ to select.
2) Press ► to start the forward or rewind search.
• When search is finished, playback begins.

Index Scan (For normal and /or timer recordings)

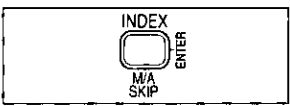
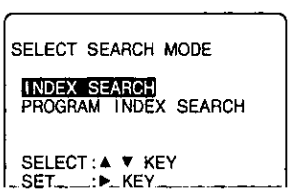
In Play mode, the first 10 seconds of each recording can be scanned (forward or reverse).

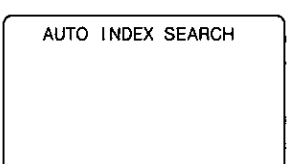
- a**  **Display SELECT SEARCH MODE.**
Press INDEX/ M/A SKIP.
• If there are no timer recordings on the Program Index List, go to step c.
- b**  **Display INDEX.**
1) Press ▲▼ to select.
2) Press ► to display.
- c**  **Start scan.**
Press FF or REW.
- d**  **Cancel scan, start playback.**
Press PLAY.
• To stop, press STOP.

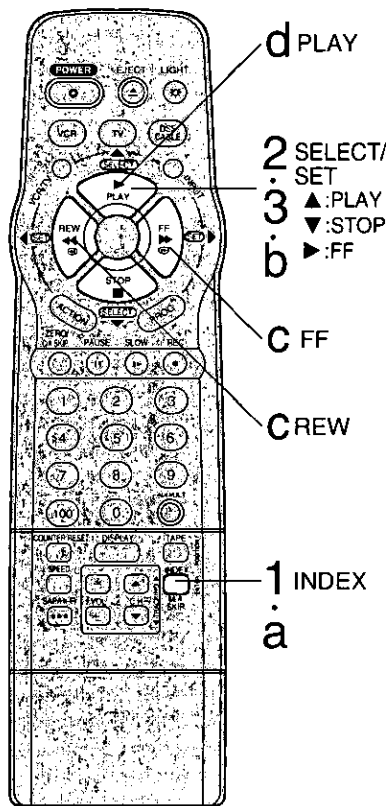
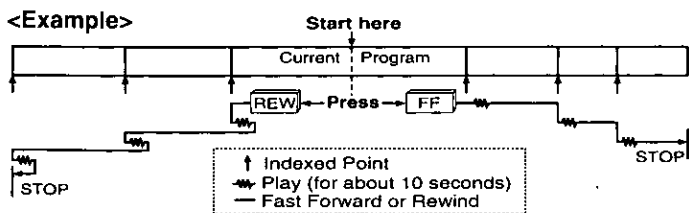

Tape Operation

Auto Operation Functions

■ Auto Playback

Tape insert --> Power turn on -->
--> Start playback if record tab
(see page 42.) is removed.

■ Auto Rewind

Playback
Manual Record } --> Tape end -->
Fast Forward }
--> Rewind (Auto)

■ Playback Auto Eject (Repeat Play is "OFF")

Playback --> Rewind -->
--> Tape eject (Without record tab)

■ Memory Rewind Off

Rewind --> Press POWER -->
--> Turn off after complete

Tape Operation (continued)

Repeat Play

Set to see a recording over and over.



Display menu.
Press ACTION.*

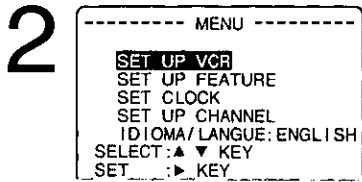

Display SET UP VCR.

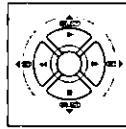

- 1) Press ▲▼ to select.
- 2) Press ► to display.

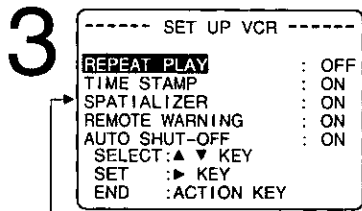

Set ON or OFF.

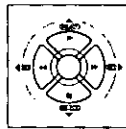

- 1) Press ▲▼ to select "REPEAT PLAY."
- 2) Press ► to set.

* Playback repeats when tape end is reached or unrecorded portion over 30 seconds is detected.

PV-9668 only

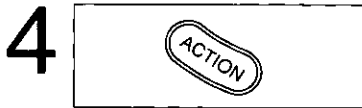

Return to normal screen.
Press ACTION twice.

Zero Search

To quickly return to specific tape counter location.

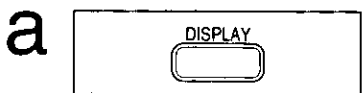

Display Counter.
Press DISPLAY during playback.

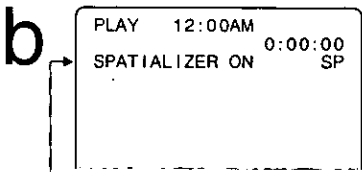

Reset to "0:00:00."

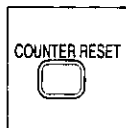

Press COUNTER RESET at the desired position.

PV-9668 only

c **Continue playback, rewind, or fast forward.**

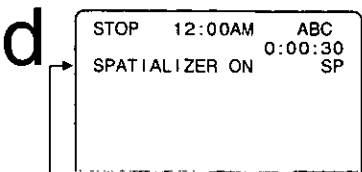

Return to "0:00:00."



Press ZERO/ C/A SKIP in Stop mode.

* The VCR will go into FF or REW mode and stop at the last point the Counter was set to 0:00:00.

PV-9668 only

*Important:

If the remote control POWER, ACTION, PROG, CH ▲▼, INDEX/ M/A SKIP, NUMBERED keys, INPUT, TAPE POSITION, or ADD/ DLT button does not work when pressed, press the VCR button on the remote and try the button again.

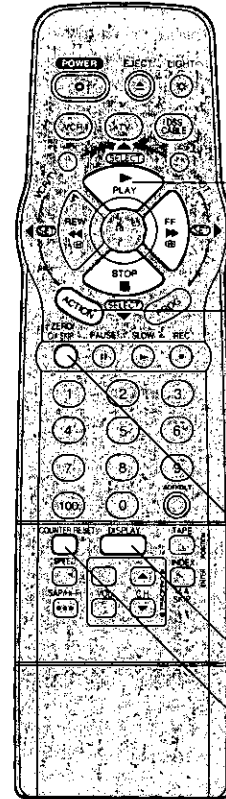

- 2 SELECT/SET
- 3 ▲:PLAY
▼:STOP
►:FF
- 1 ACTION
- 4

- d ZERO/C/A SKIP
- a DISPLAY
- b COUNTER RESET

Copying Your Tapes (Dubbing)

Connections you'll need to make. (Choose front or rear connection.)

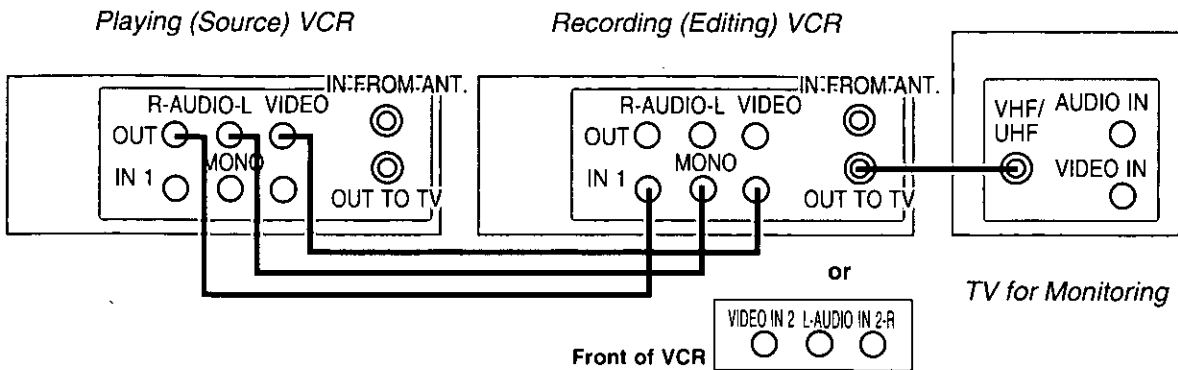

Playing (Source) VCR

Recording (Editing) VCR

1 **Insert pre-recorded tape.**

Insert blank tape with record tab.

2 **Select LINE mode.**
Press INPUT. (See "Selecting the Input Mode" below.)

3 **Put in Standby mode.**
Press PLAY, then PAUSE at starting point.

Put in Standby mode.
Press REC, then PAUSE immediately.

4 **Start dubbing.**
Press PAUSE.

Start dubbing.
Press PAUSE.

5 **Stop dubbing.**
Press STOP.

■ To Monitor Dubbing on Your TV

- 1 Turn your TV on and tune to the Recording VCR channel (CH3 or CH4).
- 2 Set the VCR/ TV Selector on the Recording VCR to "VCR."

■ Selecting the Input Mode

- Method 1: Press INPUT.
Channel Number <--> LINE1 <--> LINE2
Method 2: Press CH ▲▼. Display will change as below.

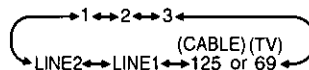

Note Dubbing tapes protected with Copy Guard will have poor quality results.

- When LINE1 or LINE2 is selected, "LINE1" or "LINE2" appears on Multi-Function Display (about 4 sec.)
- LINE1: For rear audio/video connection.
- LINE2: For front audio/video connection.

Caution: Unauthorized exchanging and/or copying of copyrighted recordings may be copyright infringement.

MTS Broadcast/VHS Hi-Fi Stereo System

✓ Check list before you begin.

- VCR is connected to a stereo TV, or a mono TV and an external stereo amp or receiver with speakers.
- VCR and other components are plugged in and turned on.

Connections to Make

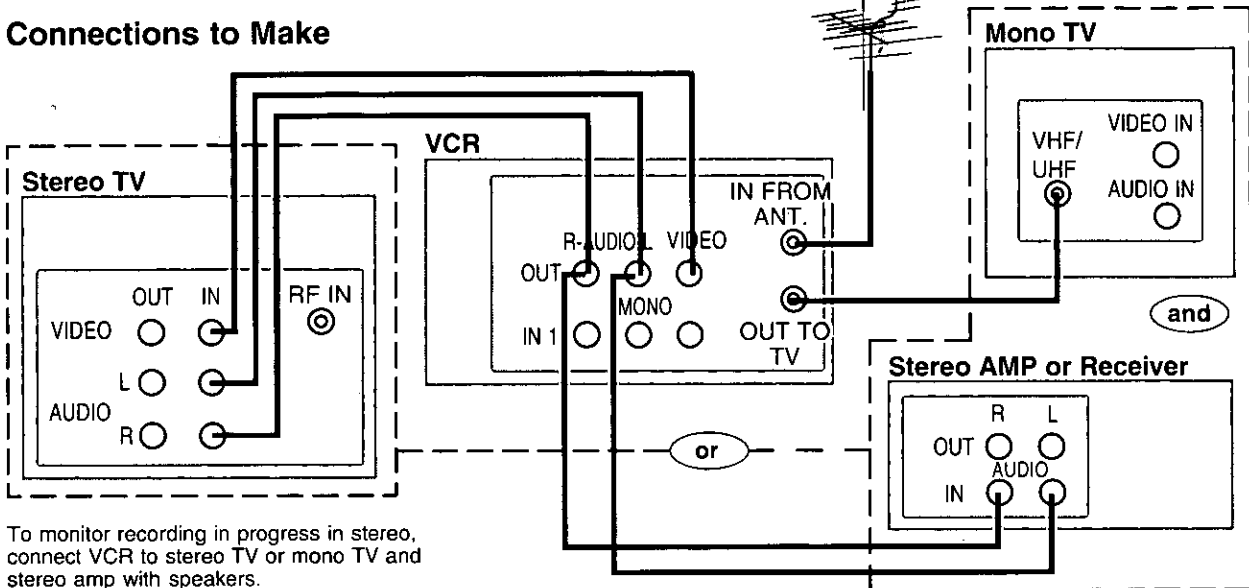

To monitor recording in progress in stereo, connect VCR to stereo TV or mono TV and stereo amp with speakers.

Receivable Broadcast Types

The following are possible audio broadcast types and on-screen displays. The signal being received is indicated with an "Ⓢ" mark while the selected audio mode is indicated with an arrow.

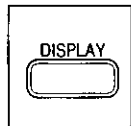

Display the broadcast signal being received. Press DISPLAY.

MTS Stereo and SAP broadcast

Multi-channel Television Sound Stereo (main language) and Secondary Audio Program (sub language) broadcasts are both being received simultaneously. Select STEREO or SAP audio mode.

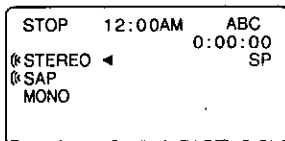

MTS Stereo broadcast

Multi-channel Television Sound Stereo broadcast. Select STEREO audio mode.

- If stereo broadcast is weak and display flickers, select MONO audio mode for possibly better results.

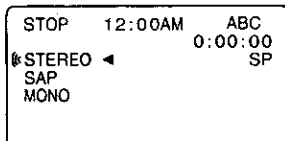

SAP broadcast

Secondary Audio Program (sub language) broadcast. Select SAP audio mode for the sub language.

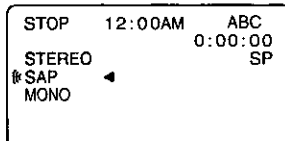

MONO broadcast

Normal monaural sound broadcast.

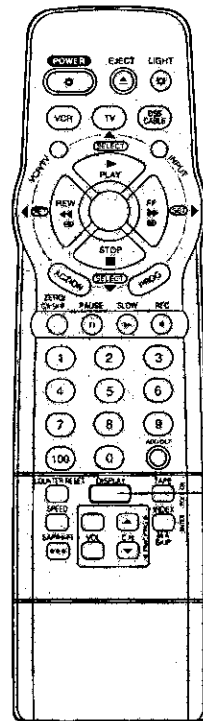
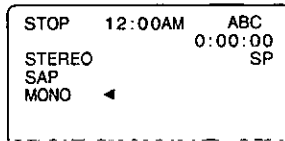

Equipped with dbx®-TV Noise Reduction for true MTS reproduction. dbx®-TV Noise Reduction is required for good stereo separation and audio fidelity. dbx® is a registered trademark, and is licensed by dbx® Technology Licensing.

Audio Mode for Recording

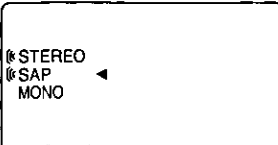
- A**  **Display audio mode.**
Press SAP/ Hi-Fi.
- B**  **Select desired mode.**
Press SAP/ Hi-Fi repeatedly (each press within 5 seconds).
- Refer to the "Receivable Broadcast Types" on page 32.
 - The arrow indicates your selection.

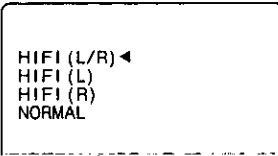

- C** **Do a recording.**
See page 13.

Audio Mode for Playback

- a** **Start playback.**
See page 12.
- b**  **Display audio mode.**
Press SAP/ Hi-Fi.
- c**  **Select desired mode.**
Press SAP/ Hi-Fi repeatedly (each press within 5 seconds).
- Select "HIFI(L/R)" or "HIFI(L)" or "HIFI(R)" to listen to stereo recordings in stereo sound. Select "NORMAL" for monaural sound.
 - The arrow indicates your selection.

Spatializer Feature (For model PV-9668 only)

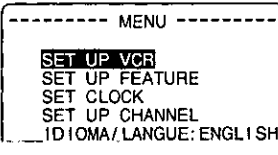
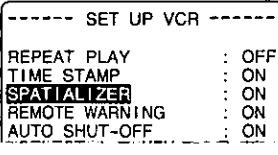
This feature allows you to enhance the stereo sound so that it seems to surround you.
Note: Your VCR needs to be hooked up to a stereo TV or stereo amp/receiver with speakers (see page 32). For playback, tapes must be recorded in Hi-Fi stereo. For TV viewing, programs must be broadcast in stereo.

- 1**  **Display menu.**
Press ACTION.
- 2**  **Display SET UP VCR.**
1) Press ▲▼ to select.
2) Press ► to display.
- 3**  **Set ON or OFF.**
1) Press ▲▼ to select.
2) Press ► to set.
- 4**  **Return to normal screen.**
Press ACTION twice.

- You can select "ON" or "OFF" by pressing PLAY key on the VCR during playback.

When set to proper audio mode VCR can:

- 1) record/playback MTS stereo broadcasts (main language) in Hi-Fi stereo.
 - 2) record/playback mono (main language) or SAP (sub language) broadcasts.
 - 3) playback non Hi-Fi tapes in monaural.
- The selected broadcast sound is always recorded on left and right Hi-Fi track as well as the normal monaural track. This means tapes can be played back on Hi-Fi and non-Hi-Fi VCRs.

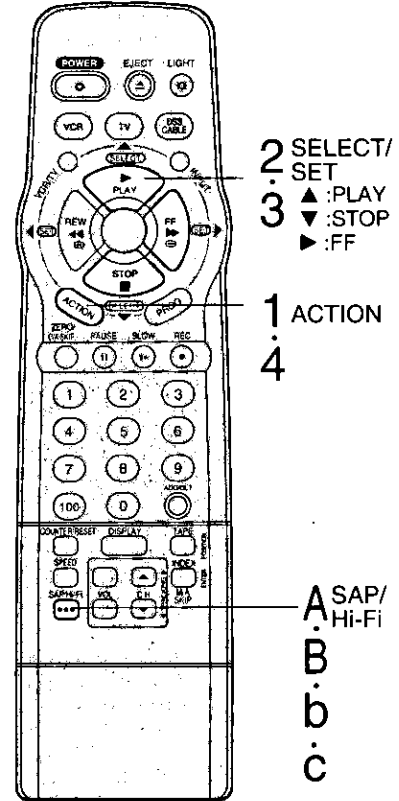

Portions of this product manufactured under a licence from Desper Products, Inc. SPATIALIZER, and the circle-in-square device are trademarks owned by Desper Products, Inc.

Notes

- Only tapes recorded in Hi-Fi stereo will play back with true stereo sound. Standard stereo tapes will play back in monaural sound.
- To listen to Hi-Fi stereo playback, the VCR AUDIO (L/R) jacks must be connected to a stereo TV or an external stereo amp and speakers. (See page 32.)
- If tracking is adjusted during playback, Hi-Fi audio may revert to normal audio.
- Hi-Fi and normal audio playback volume level may differ.

Special VCR Features

Channel Caption

When set, station name, e.g. ABC, CBS, and channel number appear on-screen.
Set up to 24 preset captions, and/or 10 manually created captions.

You need a list of stations and the channel numbers you receive them on.

Preset Caption

1  **Display menu.**
Press ACTION.*

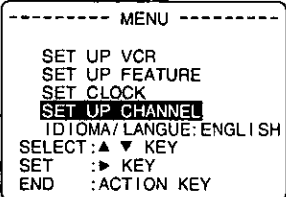
2  **Display SET UP CHANNEL.**
1) Press ▲▼ to select.
2) Press ► to display.

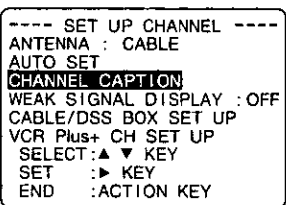
3  **Display CHANNEL CAPTION.**
1) Press ▲▼ to select.
2) Press ► to display.

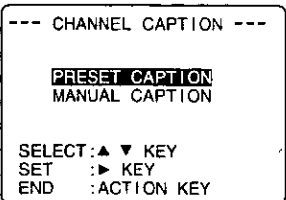
4  **Display PRESET CAPTION.**
1) Press ▲▼ to select.
2) Press ► to display.
• To create your own captions, go to "Manual Caption" on page 35.

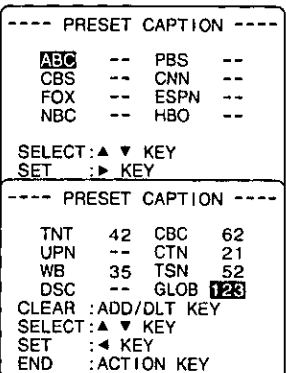
5  **Assign preset captions.**
1) Press ▲▼ to highlight caption.
2) Press ► to move cursor to the right.
3) Press ▲▼ to select CH number.
4) Press ◀ to set.
• Repeat step 5 until the list is complete.
To make corrections,
Press ▲▼ and ► to select the channel number, then press ▲▼ to change, or ADD/DLT to delete the number.

6  **End setup.**
Press ACTION four times.

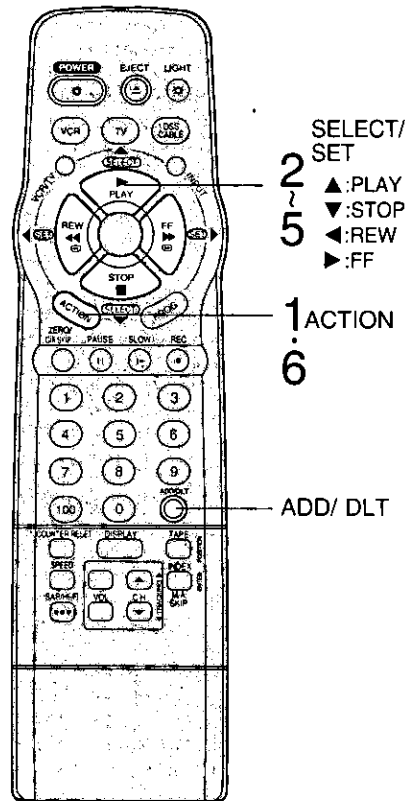

*Important: If the remote control POWER, ACTION, PROG, CH▲/▼, INDEX/ M/A SKIP, NUMBERED keys, INPUT, TAPE POSITION, or ADD/DLT button does not work when pressed, press the VCR button on the remote and try the button again.

Manual Caption

1 Do "Preset Caption" steps 1~3 on page 34.

2 **Display MANUAL CAPTION.**

--- CHANNEL CAPTION ---

PRESET CAPTION
MANUAL CAPTION

SELECT: ▲ ▼ KEY
SET : ► KEY
END : ACTION KEY

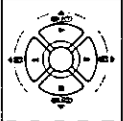

1) Press ▲▼ to select.

2) Press ► to display.

3 **Select channel number.**

--- MANUAL CAPTION ---

CH NUMBER	CAPTION
02	---

SELECT: ▲ ▼ KEY
SET : ► KEY
END : ACTION KEY

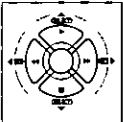

1) Press ▲▼ to select CH NUMBER.

2) Press ► to move cursor to the right.

- Channels already set and channels deleted from Channel Memory are not displayed.
- You can set a total of ten channel captions.

4 **Enter CAPTION.**

--- MANUAL CAPTION ---

CH NUMBER	CAPTION
02	A---

CLEAR : ADD/DLT KEY
SELECT: ▲ ▼ KEY
SET : ► KEY

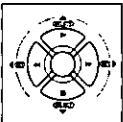

1) Press ▲▼ to select.

2) Press ► to enter.

• Characters change in following order.

→ A ↔ B ↔ C ↔ ... ↔ Z ↔ BLANK ↔ - ↔ & ↔

→ 9 ↔ 2 ↔ 1 ↔ 0 ↔ / ↔ ! ↔

3) Press ◀ to set.

- Repeat steps 3 and 4 as desired.

To make corrections,

Press ◀▶ to move to the incorrect entry, then press ▲▼ to make correction. Or, press ADD/DLT to clear the caption.

5 **End input.**
Press ACTION four times.



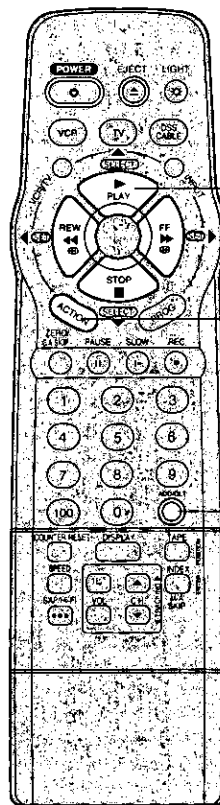

- 2** SELECT/SET
3 ▲:PLAY
▼:STOP
4 ◀:REW
▶:FF
5 ACTION

ADD/ DLT

Special VCR Features

Special VCR Features (continued)

Time Stamp Feature

The VCR writes program data (see example below) about the first 10 seconds of every recording. The information is then displayed the first 10 seconds of playback. To change the data, see "Changing Time Stamp Data" on page 37.



Display menu.
Press ACTION.*

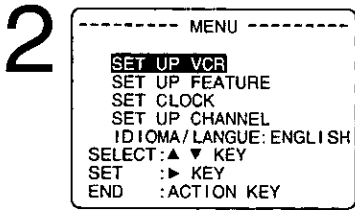

Display SET UP VCR.
1) Press ▲▼ to select.
2) Press ► to display.

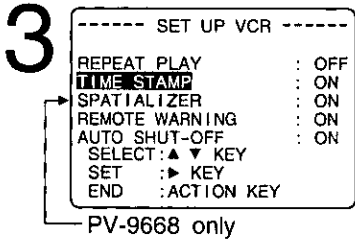
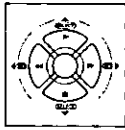

Set ON or OFF.
1) Press ▲▼ to select.
2) Press ► to set.

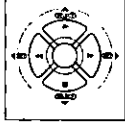

* When "OFF" is selected, the program data is written on the tape, but will not be displayed.

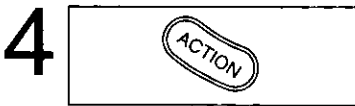

Return to normal screen.
Press ACTION twice.

Check list before you begin.

- Clock is set to correct time.
- Record tab in place. (See page 42.)

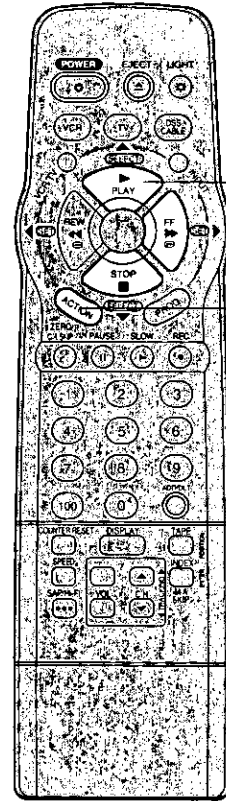

- 2** SELECT/SET
- 3** ▲:PLAY
▼:STOP
►:FF
- 1** ACTION
- 4**

<Time Stamp Example>

One Touch Recording

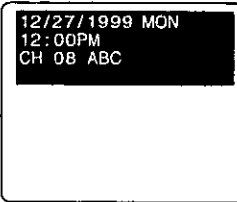

Timer Recording

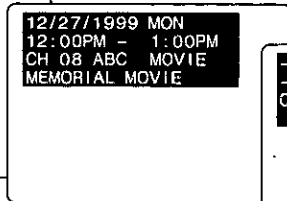

When Clock is not set...

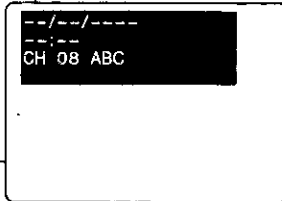

Important: If the remote control POWER, ACTION, PROG, CH▲/▼, INDEX/M/A SKIP, NUMBERED keys, INPUT, TAPE POSITION, or ADD/HLT button does not work when pressed, press the VCR button on the remote and try the button again.

Changing Time Stamp Data

You may change the Date, Time, Channel, Category, and Notes.

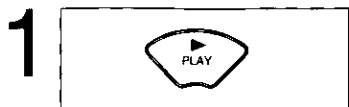

Display Time Stamp Data.

- 1) Insert cassette with record tab.
- 2) Press PLAY.

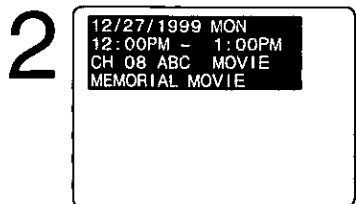

Display TIME STAMP EDIT.

-  Press PROG while the data is displayed in Playback mode.

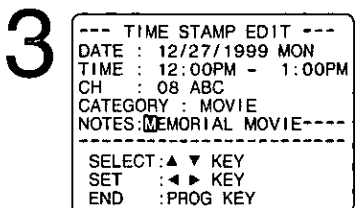

Change Time Stamp Data.

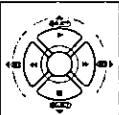
-  1) Press ▲▼ to select.
2) Press ► to enter and continue.

- Characters in NOTES will change in the following order.

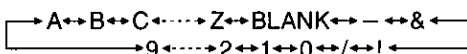

- 3) Repeat 1) and 2) as needed.

To make corrections,

Press ◀▶ to move to the incorrect entry, then press ▲▼ to make the correction.

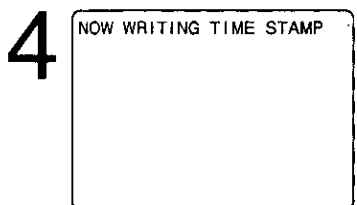

Write the new data.

-  Press PROG.

- When data is written, VCR returns to Stop mode.

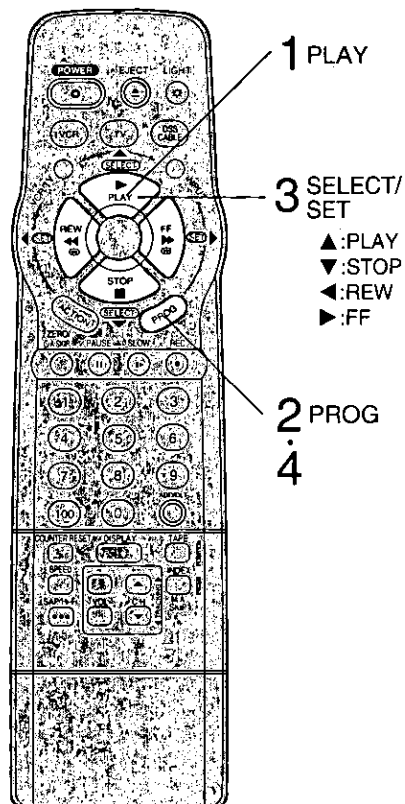
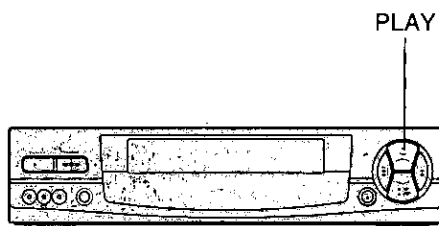

Special VCR Features

Special VCR Features (continued)

Tape Position Display Feature

To find out the present tape position.
Tape position cannot be found for C-Cassette type and tape of less than 60 minutes.

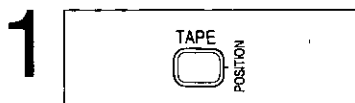

Detect Tape Position.
Press TAPE POSITION.*

DETECTING TAPE POSITION

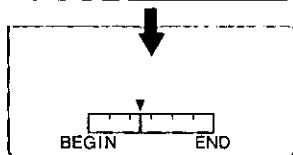

- Detecting tape position is only displayed when cassette is first inserted.
- It takes several seconds for correct indication to appear.
- Indication is standard.

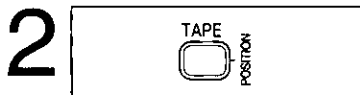

Return to normal screen.
Press TAPE POSITION.

Check list before you begin.

- All connections are made. (See pages 4-5.)
- VCR is plugged in.
- TV is turned on and set to the VCR channel (CH 3 or 4).

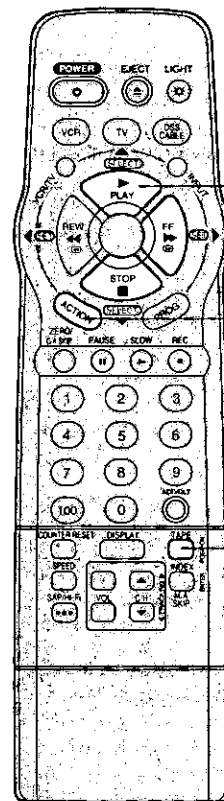
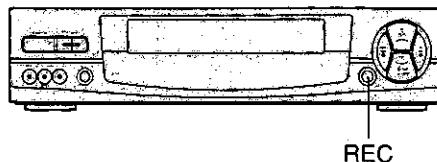

b SELECT/SET

c ▲:PLAY
▼:STOP
▶:FF

a ACTION

d

1 TAPE POSITION
2

Remote Warning ON/OFF Feature

If Multi-brand feature is used (page 22), and this feature is set to on, a warning appears whenever an invalid key is pressed in TV, DSS, or Cable mode.

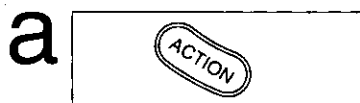

Display menu.
Press ACTION.

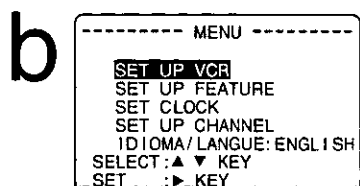

Display SET UP VCR.

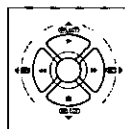

- 1) Press ▲▼ to select.
- 2) Press ▶ to display.

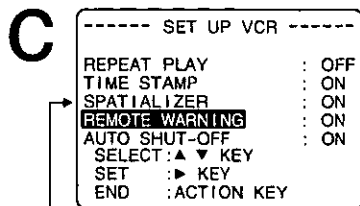

Set ON or OFF.

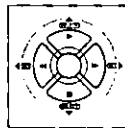

- 1) Press ▲▼ to select.
- 2) Press ▶ to set.

• "OFF" -> Remote Warning will not appear even if invalid key is pressed.

PV-9668 only

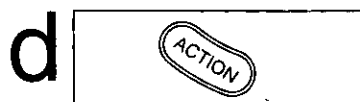

Return to normal screen.
Press ACTION twice.

VCR Lock Feature

All operations are prohibited except timer recording and tape eject. Useful for families with small children.

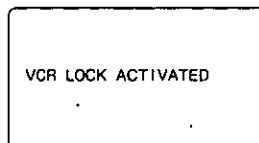

To turn ON:
In Stop mode, hold down REC on the VCR without a cassette inserted for 7 seconds.

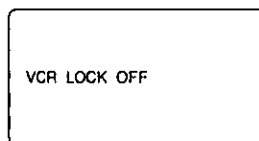

To turn OFF:
Repeat above.

• VCR Lock is canceled automatically after 24 hours if clock is set.

Important: If the remote control POWER, ACTION, PROG, CH▲/▼, INDEX/M/A SKIP, NUMBERED keys, INPUT, TAPE POSITION, or ADD/HLT button does not work when pressed, press the VCR button on the remote and try the button again.

Weak Signal Display ON/OFF Feature

When "ON" is selected, picture is displayed even when broadcast signal is weak or nonexistent.



Display menu.
Press ACTION.

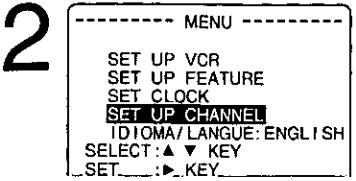

Display SET UP CHANNEL.

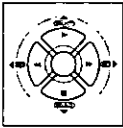

1) Press ▲▼ to select.
2) Press ► to display.

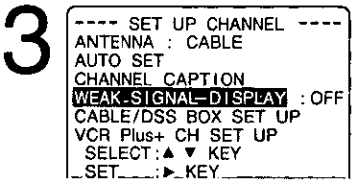

Set ON or OFF.

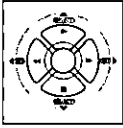

1) Press ▲▼ to select.
2) Press ► to set.

- ON --> Picture is displayed regardless of signal condition, and may not always be clearly visible.
- OFF --> Screen turns solid blue when signal is absent or weak.
- If VCR is connected to equipment which has blue back feature, selecting ON will have no effect on the other equipment.

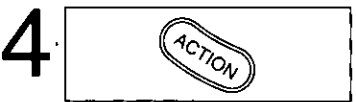

Return to normal screen.
Press ACTION twice.

Auto Shut-Off Feature

When "ON" is selected, VCR shuts itself off when playback of a blank portion of tape continues or no signal (except when LINE is selected) is detected for over 5 minutes.

a Repeat step "a" and "b" on page 38 to display SET UP VCR.

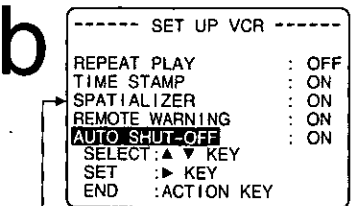

Set ON or OFF.

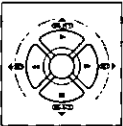

1) Press ▲▼ to select.
2) Press ► to set.

PV-9668 only

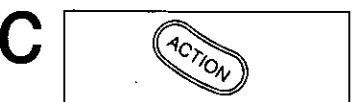

Return to normal screen.
Press ACTION twice.

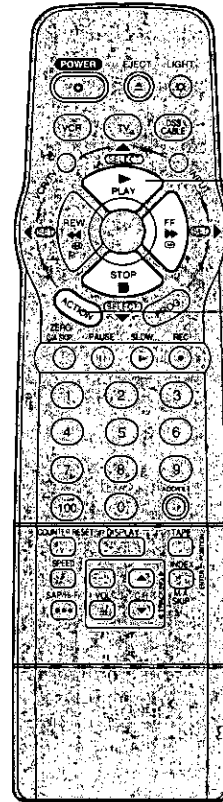

2 SELECT/SET
3 ▲:PLAY
▼:STOP
b ►:FF
1 ACTION
4
c

Special VCR Features

Reset Language, Channels, Clock

1

```

----- MENU -----
SET UP VCR
SET UP FEATURE
SET CLOCK
SET UP CHANNEL
IDIOMA/LANGUE: ENGLISH
SELECT: ▲ ▼ KEY
SET : ► KEY
END : ACTION KEY
    
```



Display menu.
Press ACTION.*

2 Language

1) Press ▲▼ to highlight language item.

```

----- MENU -----
SET UP VCR
SET UP FEATURE
SET CLOCK
SET UP CHANNEL
IDIOMA/LANGUE: ENGLISH
SELECT: ▲ ▼ KEY
SET : ► KEY
END : ACTION KEY
    
```

2) Press ► repeatedly.

```

----- MENU -----
SET UP VCR
SET UP FEATURE
SET CLOCK
SET UP CHANNEL
IDIOMA/LANGUE: ENGLISH
SELECT: ▲ ▼ KEY
SET : ► KEY
END : ACTION KEY
    
```

For English

```

----- MENU -----
PREPARAR VCR
FIJACION DE FUNCIONES
FIJAR RELOJ
FIJAR CANAL
LANGUE/LANGUE: ESPAÑOL
ELEGIR: ▲ ▼
FIJAR : ►
TERMINAR: ACTION
    
```

For Spanish

```

----- MENU -----
REGLAGE MAGNETOSCOPE
REGLAGE MAGNETO SUPPLEM
REGLAGE HORLOGE
REGLAGE CANAL
LANGUAGE/IDIOMA: FRANÇAIS
SEL. : ▲ ▼
REGLER: ►
FIN : ACTION
    
```

For French

Channels

1) Press ▲▼ to select SET UP CHANNEL.

```

----- MENU -----
SET UP VCR
SET UP FEATURE
SET CLOCK
SET UP CHANNEL
IDIOMA/LANGUE: ENGLISH
SELECT: ▲ ▼ KEY
SET : ► KEY
END : ACTION KEY
    
```

2) Press ►.

```

----- SET UP CHANNEL -----
ANTENNA : CABLE
AUTO SET
CHANNEL CAPTION
WEAK SIGNAL DISPLAY : OFF
CABLE/DSS BOX SET UP
VCR Plus+ CH SET UP
SELECT: ▲ ▼ KEY
SET : ► KEY
END : ACTION KEY
    
```

3) Press ▲▼ to select "ANTENNA," then press ► to set your antenna system (TV or CABLE).

4) Press ▲▼ to select "AUTO SET," then press ►.

* If you use a cable box, set it to the PBS channel in your time zone.

```

CHANNEL/CLOCK AUTO SET
CONNECT ANTENNA CABLE
AND IF YOU USE A CABLE
BOX, TUNE IT TO YOUR
LOCAL PBS CH THEN...
PLEASE PUSH CH UP KEY
    
```

(This screen appears only when auto clock is set.)

5) Press CH ▲.

* Clock Auto Set will be performed when channels are replaced in memory.

Clock

1) Press ▲▼ to select SET CLOCK.

```

----- MENU -----
SET UP VCR
SET UP FEATURE
SET CLOCK
SET UP CHANNEL
IDIOMA/LANGUE: ENGLISH
SELECT: ▲ ▼ KEY
SET : ► KEY
END : ACTION KEY
    
```

2) Press ►.

```

----- SET CLOCK -----
AUTO CLOCK SET
MANUAL
TIME ZONE ADJUST : 0
SELECT: ▲ ▼ KEY
SET : ► KEY
END : ACTION KEY
    
```

("TIME ZONE ADJUST" appears only when clock is set automatically.)

3) Press ▲▼ to select MANUAL and press ►.

* For Auto Clock Set, select "AUTO CLOCK SET," then press CH ▲.

```

----- SET CLOCK -----
1/ 4/2000 TUE 12:00PM
DST: ON
SELECT HOUR
SELECT: ▲ ▼ KEY
SET : ◀ ▶ KEY
END : ACTION KEY
    
```

4) Press ▲▼ and ◀▶ to select and set the date, time, and DST (Daylight Saving Time).

5) Press ACTION twice to start the clock and exit this mode.

* For Auto Clock Set, select AUTO CLOCK SET, then follow On Time VCR Setup instructions on page 8-11.

*Important: If the remote control POWER, ACTION, PROG, CH▲/▼, INDEX/ M/A SKIP, NUMBERED keys, INPUT, TAPE POSITION, or ADD/HLT button does not work when pressed, press the VCR button on the remote and try the button again.

Add or Delete a Channel

To add channel:

Select channel with NUMBERED keys and press ADD/HLT.

To delete channel:

Select channel with CH ▲/▼ or NUMBERED keys and press ADD/HLT.

CHANNEL 08 ADDED

CHANNEL 08 DELETED

Time Zone Adjust

(When Auto Clock is set only.)

- 1) Press ▲/▼ to select SET CLOCK.

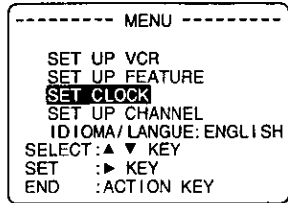

- 2) Press ►.

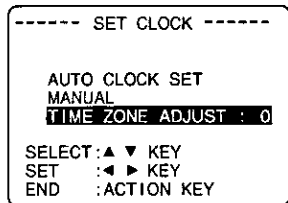

- 3) Press ▲/▼ to select TIME ZONE ADJUST and press ◄ or ► to subtract or add hour(s) as necessary.

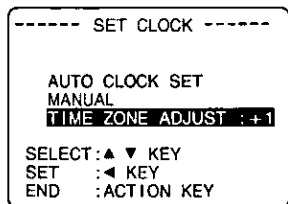

- 4) Press ACTION twice.

- 5) Press POWER off to perform AUTO CLOCK SET.

- TIME ZONE ADJUST returns to "0" if clock is set manually.

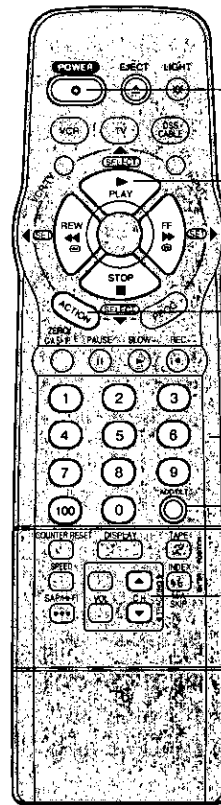

POWER

SELECT/ SET

▲:PLAY

▼:STOP

◄:REW

►:FF

ACTION

NUMBERED keys

ADD/DELETE

CH ▲/▼

Using ▲▼◄► keys

You can also operate the menu screen using VCR buttons.

If you use VCR buttons, press CH ▲ and CH ▼ together to display the menu screen.

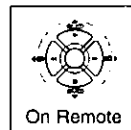

▲ : PLAY

▼ : STOP

◄ : REW

► : FF

When menu screens are displayed, PLAY, STOP, REWIND, and FF buttons function as ▲▼◄► only.

VCR & Cassette Information

Reset All VCR Memory Functions

Use when moving VCR to new location, or if a mistake was made in the One Time VCR Setup section.

- Make sure a tape is not inserted in the VCR.

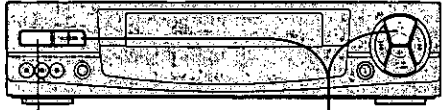

1 Turn VCR Power on.

2 Press and hold both **PLAY** and **CHANNEL ▲** on the VCR for more than 5 seconds.
• The power will shut off.

3 Do "One Time VCR Setup" steps on page 8.

Prevent Accidental Tape Erasure

Break off the tab.

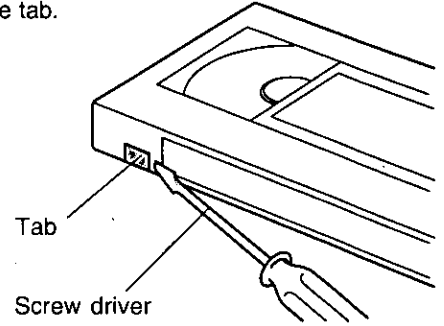

To record again

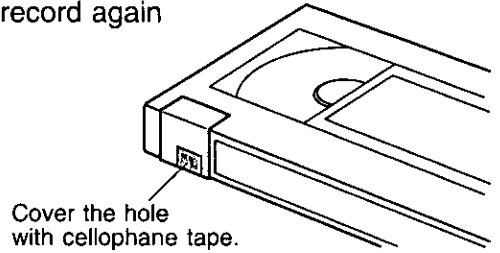

DST (Daylight Saving Time)

VCR auto adjusts clock for DST. (Page 11.)

Spring (First Sunday in April)

DST:ON --> sets clock ahead one hour.

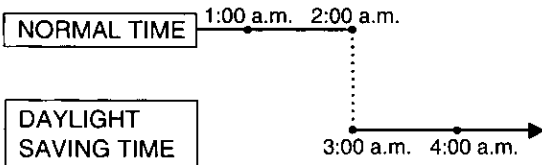

Autumn (Last Sunday in October)

DST:ON --> Turns clock back one hour.

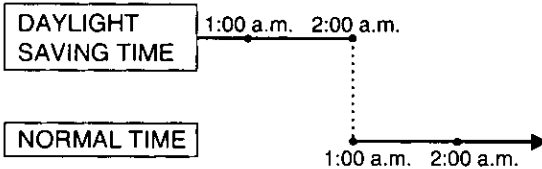

- If your area does not observe Daylight Saving Time, select DST:OFF.
- Keep these time changes in mind when programming the VCR for timer recordings.

Record/Playback Time

Only use tapes with the **VHS** mark in this unit.

Tape Speed Setting	Type of Video Cassette		
	T60	T120	T160
SP (Standard Play)	1 Hour	2 Hours	2 Hours 40 Minutes
LP (Long Play)	2 Hours	4 Hours	5 Hours 20 Minutes
SLP (Super Long Play)	3 Hours	6 Hours	8 Hours

Head Cleaning

Playing older or damaged tapes may eventually cause video heads to become clogged.

Video Head Clog Sensor

During playback this screen appears if clogging is detected. To remove screen, press PLAY on the remote or VCR.

VIDEO HEADS MAY
NEED CLEANING
PLEASE INSERT HEAD
CLEANING CASSETTE
OR REFER TO MANUAL

END:PLAY KEY

- Use "dry" type head cleaning cassette only. (Part No. NV-TCL30PT is recommended.)

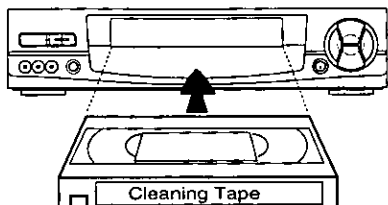

- Follow cleaning tape instructions carefully. Excessive use of tape can shorten head life.
- If head clog symptoms persist, contact your nearest Factory Service Center or authorized Service Center. (See page 46.)

Built-in Head Cleaner

A clean video head helps produce a clear picture.

So, we have equipped your VCR with a built-in, non-chemical head cleaning system that helps prevent clogging of the video heads. Cleaning is performed each time you load or unload a video cassette.

- This feature is preventative only. If your video heads are seriously clogged, consider the use of a chemical non-abrasive head cleaning kit or take your VCR to a Service Center.

Cleaning the VCR

Use a soft cloth or dusting attachment of your vacuum cleaner to dust your VCR. Remove dust from the ventilation holes on the back sides and bottom of the cabinet.

Plastic surfaces are easily scratched and can be marred by alcohol and various solvents. Avoid excessive use of oil-based furniture polishes since the materials used in the cabinet will accumulate more dust. We recommend using a nonabrasive, antistatic cleaner and polisher.

Specifications

Power Source:	120V AC, 60 Hz
Power Consumption:	Approx. 23 watts (Power On) Approx. 3.3 watts (Power Off)
Video Signal:	EIA Standard NTSC color
Video Recording System:	4 rotary heads helical scanning system
Audio Track:	1 track (Normal) 2 channel (Hi-Fi Audio Sound)
Tuner:	
Broadcast Channels:	VHF 2-13, UHF 14-69
CABLE Channels:	Midband A through I (14-22) Superband J through W (23-36) Hyperband AA-EEE (37-64) Lowband A-5-A-1 (95-99) Special CABLE channel 5A (01) Ultraband 65-94, 100-125
Operating Temperature:	41°F-104°F (5°C-40°C)
Operating Humidity:	10%-75%
Weight:	9.9 lbs. (4.5 kg)
Dimensions:	16-15/16" (W) x 3-7/8" (H) x 11-13/16" (D) 430 (W) x 98 (H) x 300 (D) mm

Note: Designs and specifications are subject to change without notice.

Features for a Quality Picture

Digital Auto Picture

Automatically controls the video output signal for less noise depending on the tape condition.

Digital Auto Tracking

Continuously analyzes the signal and adjusts for optimum picture quality.

Manual Tracking Control (to reduce picture noise)

Use during Playback and Slow Motion mode to reduce picture noise. To return to Auto Tracking, press POWER off, then on again.

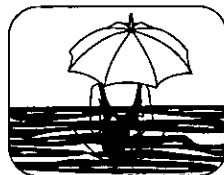

V-Lock Control (to reduce picture jitter)

In Still mode, CH (TRACKING) ▲/▼ operate as a V-Lock control.

DynAmorphous™ Metal Head/ CNR (Color Noise Reduction)/ ANR (Advanced Noise Reduction)

DynAmorphous™ Metal Head increases playback and record picture quality. Color Noise Reduction reduces the color noise. Advanced Noise Reduction reduces the luminance noise.

On-Screen Displays (OSD)

Function & Channel Display

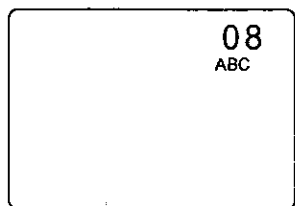

When a function button is pressed, e.g. PLAY, or you change channels, a 4 second display appears first in large and then small characters. (Some Station names may also appear if Channel Caption is set. See page 34, 35.)

Blank Tape/ No Video Signal Indication

Whenever a blank section of a tape comes up in Play mode, or when the selected channel has no broadcast signal with the Weak Signal Display Feature (page 39) set to OFF, the TV screen will turn solid blue.

VCR Status & Clock Display

To display or remove the overlay.

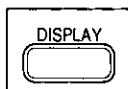

Press DISPLAY.

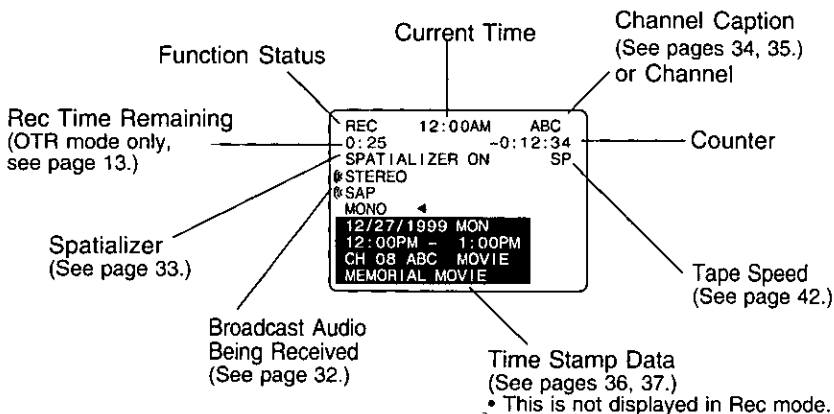

Warning and Instruction Displays

These displays will alert you of a missed operation or provide further instructions.

OSD	Caution	Pg	OSD	Caution	Pg
NO CH FOUND PLEASE CHECK ANTENNA CABLE CONNECTION THEN PUSH VCR CH UP KEY AGAIN	If no active channels are found for CHANNEL MEMORY...	10	TO CANCEL TIMER REC PUSH POWER THEN STOP KEY	If you press POWER or STOP during a Timer Recording... (visible in VCR mode only)	17
PLEASE SET CLOCK BEFORE PROGRAMMING	If you attempt to set or review a Timer Recording and the Clock is not set..	16 17	VIDEO HEADS MAY NEED CLEANING PLEASE INSERT HEAD CLEANING CASSETTE OR REFER TO MANUAL END: PLAY KEY	If head cleaning becomes necessary while playing back a tape...	43
TURN VCR OFF FOR TIMER RECORDING AND LEAVE CABLE BOX POWER ON	After a Timer Program has been set...	17	VCR LOCK ACTIVATED	If you press a function button other than STOP/ EJECT or POWER while the VCR is in VCR Lock mode...	38
CHECK CASSETTE RECORD TAB	If you press REC on the remote control or VCR, and a cassette is inserted with no record tab...	42	REMOTE CONTROL IS SET TO CABLE/DSS MODE USE VCR : VCR KEY USE TV : TV KEY	If you press any invalid keys on the remote while in CABLE/DSS mode...	22 23
NO CASSETTE PLEASE INSERT A CASSETTE	If you press PLAY, FF, REW, or REC on the remote control or VCR without a cassette inserted...	12 13	REMOTE CONTROL IS SET TO TV MODE USE VCR : VCR KEY USE CABLE/DSS : CABLE/DSS	If you press any invalid keys on the remote while in TV mode...	22 23

Before Requesting Service

Check the following points once again if you are having trouble with your VCR.

Power	Correction
No power...	<ul style="list-style-type: none"> • Completely insert Power Plug into an AC outlet. • Set POWER button to ON. • Make sure power source is active.
Recording & Playback	Correction
TV program cannot be recorded...	<ul style="list-style-type: none"> • Check connections between VCR, external antenna, and TV. • Check hook up selection. (P.4~5) • Make sure your antenna system (CABLE or TV) is correctly set. (Channels (P.40)) • Make sure cassette record tab is intact. (P.42)
Timer recording cannot be performed...	<ul style="list-style-type: none"> • Check clock is set to current time and date. • Make sure Cable/DSS box (if used) is left on and tuned to channel to be recorded. • Set recording start/stop times correctly. (P.16) • Make sure POWER button is set to OFF. (P.17) • Timer recording may not be performed or continued if a power interruption of more than 1 minute occurs before or during, a Timer Recording, even after power is restored.
There is no playback picture, or the playback picture is noisy or contains streaks...	<ul style="list-style-type: none"> • Select channel 3 or 4 on TV to match Channel 3/4 switch on rear panel of VCR (P.4) or select LINE. • Set VCR/TV selector to "VCR." • Adjust TRACKING control in either direction. (P.43) • Try Head Cleaning. (P.43)
Special effects playback, picture may contain some vertical jitter when using a TV with an Automatic Vertical Hold Control...	<ul style="list-style-type: none"> • Set TV's Vertical Hold Control to "MANUAL" then adjust.
VCR cannot be controlled...	<ul style="list-style-type: none"> • Make sure VCR LOCK is set to off. (P.38) • Make sure remote is in proper mode. • Make sure unit is not in a Timer Record operation.
Remote Control	Correction
VCR cannot be remote controlled...	<ul style="list-style-type: none"> • Aim Remote Control directly at remote sensor on VCR. (P.52) • Avoid any object blocking signal path. • Inspect remote batteries. (P.4) • Make sure VCR LOCK is set to off. (P.38) • Exposing VCR remote sensor to direct fluorescent or outdoor light may cause signal interference.
ACTION and PROG buttons cannot be used...	<ul style="list-style-type: none"> • Press VCR button for VCR mode. (P.22) • Check Batteries.
Miscellaneous	Correction
Programs cannot be viewed on TV...	<ul style="list-style-type: none"> • Set VCR/TV selector to "TV." (P.13) • Make sure proper signal source is selected.
Video cassette cannot be inserted...	<ul style="list-style-type: none"> • Insert the cassette with window side up; record tab facing you.. • Insure no other tape is inside unit.
Video cassette cannot be removed...	<ul style="list-style-type: none"> • Completely insert Power Plug into AC outlet.
Video cassette ejects when a recording is started or the power is turned off for timer recording...	<ul style="list-style-type: none"> • Make sure cassette rec tab is intact. (P.42)
In Stop mode, the motor (CYLINDER) continues to rotate...	<ul style="list-style-type: none"> • To enable Quick play mechanism, the cylinder will rotate for about 5 minutes. This reduces response time from Stop to Play mode and from Play to Rewind Search mode.
The top of the playback picture waves back and forth excessively...	<ul style="list-style-type: none"> • Because VCR playback signal is not as stable as off-the-air TV signal, top of TV screen may be bent or unstable during playback. Slowly turn TV horizontal Hold control to correct. If your TV has no horizontal Hold control or adjusting control is ineffective, contact your nearest TV service center.

If you cannot resolve the problem, please call the Customer Satisfaction Center for product assistance at 201-348-9090.

To locate an authorized servicenter, please call toll free 1-800-211-PANA (7262).

Service Center List

For Product Information, Operating Assistance, Literature Request, Dealer Locations, and all Customer Service inquiries please contact:

1-800-211-PANA (7262), Monday-Friday 9am-9pm Saturday-Sunday 9am-7pm, EST.

Web Site: <http://www.panasonic.com>

You can purchase parts, accessories or locate your nearest servicer by visiting our Web Site.

Accessory Purchases:

Customer Orders Only 800-332-5368 (Customer Orders Only)

Panasonic Services Company 20421 84th Avenue South, Kent, WA 98032

(6 am to 5 pm Monday - Friday; 6 am to 10:30 am Saturday; PST)

(Visa, MasterCard, Discover Card, American Express, Check)

Factory Servicenters Locations

CALIFORNIA

6550 Katella Avenue
Cypress, CA 90630

800 Dubuque Avenue
S. San Francisco,
CA 94080

20201 Sherman Way
Suite 102
Canoga Park, CA 91306

3878 Ruffin Road
Suite A
San Diego, CA 92123

COLORADO

1640 South Abilene Street
Suite D
Aurora, CO 80012

FLORIDA

3700 North 29th Avenue
Suite 102
Hollywood, FL 33020

GEORGIA

8655 Roswell Road
Suite 100
Atlanta, GA 30350

ILLINOIS

9060 Golf Road
Niles, IL 60714

1703 North Randall
Road
Elgin, IL 60123
(Pick-up / Drop-off only)

MARYLAND

62 Mountain Road
Glen Burnie, MD 21061

MASSACHUSETTS

60 Glacier Drive
Suite G
Westwood, MA 02090

MICHIGAN

37048 Van Dyke Avenue
Sterling Heights, MI 48312

MINNESOTA

7850-12th Avenue South
Airport Business Center
Bloomington, MN 55425

OHIO

2236 Waycross Road
Civic Center Plaza
Forest Park, OH 45240

PENNSYLVANIA

2221 Cabot Blvd. West
Suite B
Langhorne, PA 19047

Chartiers Valley
Shopping Center
1025 Washington Pike
Bridgeville, PA 15017

TENNESSEE

3800 Ezell Road
Suite 806
Nashville, TN 37203

TEXAS

7482 Harwin Drive
Houston, TX 77036

13615 Welch Road
Suite 101
Farmers Branch,
TX 75244

WASHINGTON

20425-84th Avenue South
Kent, WA 98032

HAWAII

99-859 Iwaiwa Street
Aiea, Hawaii 96701
Phone (808)488-1996
Fax (808)486-4369

Service in Puerto Rico

Matsushita Electric of Puerto Rico, Inc. Panasonic Sales Company/ Factory Servicer:

Ave. 65 de Infanteria, Km. 9.5, San Gabriel Industrial Park, Carolina, Puerto Rico 00985

Phone (787)750-4300 Fax (787)768-2910

As of April '98

Warranty

Panasonic Consumer Electronics Company,
Division of Matsushita Electric Corporation
of America,
One Panasonic Way
Secaucus, New Jersey 07094

Panasonic Sales Company,
Division of Matsushita Electric of Puerto Rico, Inc.
AVE. 65 de Infantería, Km. 9.5
San Gabriel Industrial Park
Carolina, Puerto Rico 00985

PANASONIC Video Products Limited Warranty

Panasonic Consumer Electronics Company or Panasonic Sales Company (collectively referred to as "the Warrantor") will repair this product with new or refurbished parts, free of charge, in the USA or Puerto Rico, in the event of a defect in materials or workmanship as follows (all time periods commence from the date of the original purchase):

PRODUCT	PARTS	LABOR
CAMCORDER	ONE (1) YEAR, EXCEPT CCD IMAGE SENSOR CCD IMAGE SENSOR - SIX (6) MONTHS	NINETY (90) DAYS NINETY (90) DAYS
VCR	ONE (1) YEAR	NINETY (90) DAYS
A/V MIXER	ONE (1) YEAR	NINETY (90) DAYS
MONITOR-VCR	ONE (1) YEAR, EXCEPT CRT CRT - TWO (2) YEARS	NINETY (90) DAYS CRT - NINETY (90) DAYS CUSTOMER PAYS ALL LABOR CHARGES AFTER 90 DAYS

Monitor-VCR In-home or carry-in Service: 22" (diagonal) CRT / LCD and Larger
Monitor-VCR Carry-in Service: 21" (diagonal) CRT / LCD and smaller

Batteries (if included) - New rechargeable batteries in exchange for defective rechargeable batteries for ten (10) days. Non-rechargeable batteries are not warranted.

Tape (if included) - New video cassette tape in exchange for a defective video cassette tape for five (5) days.

In-home, carry-in or mail-in service, as applicable, in the USA can be obtained during the warranty period by contacting a Panasonic Services Company (PASC) Factory Servicenter listed in the Service Directory. Or call toll free 1-800-211-PANA (7262), to locate an authorized PASC Servicenter. Carry-in or mail-in service in Puerto Rico can be obtained during the warranty period by calling the Panasonic Sales Company telephone number listed in the Servicenter Directory.

This warranty is extended only to the original purchaser. A purchase receipt or other proof of the date of the original purchase is required before warranty service is rendered.

This warranty only covers failures due to defects in materials and workmanship which occur during normal use and does not cover normal maintenance, including, but not limited to, video and audio head cleaning. The warranty does not cover damage which occurs in shipment, or failures which are caused by products not supplied by the warrantor, or failures which result from accident, misuse, abuse, neglect, mishandling, misapplication, alteration, modification, faulty installation, set-up adjustments, improper antenna, inadequate signal pickup, maladjustment of consumer controls, improper operation, power line surge, improper voltage supply, lightning damage, commercial use such as hotel, office, restaurant, or other business or rental use of the product, or service by anyone other than a PASC Factory Servicenter or a PASC authorized Servicenter, or damage that is attributable to acts of God.

LIMITS AND EXCLUSIONS

There are no express warranties except as listed above.

THE WARRANTOR SHALL NOT BE LIABLE FOR INCIDENTAL OR CONSEQUENTIAL DAMAGES (INCLUDING, WITHOUT LIMITATION, DAMAGE TO TAPES) RESULTING FROM THE USE OF THIS PRODUCTS, OR ARISING OUT OF ANY BREACH OF THE WARRANTY. ALL EXPRESS AND IMPLIED WARRANTIES, INCLUDING THE WARRANTIES OF MERCHANTABILITY AND FITNESS FOR PARTICULAR PURPOSE, ARE LIMITED TO THE APPLICABLE WARRANTY PERIOD SET FORTH ABOVE. Some states do not allow the exclusion or limitation of incidental or consequential damages, or limitations on how long an implied warranty lasts, so the above exclusions or limitations may not apply to you.

This warranty gives you specific legal rights and you may also have other rights which vary from state to state.

If a problem with this product develops during or after the warranty period, you may contact your dealer or Servicenter. If the problem is not handled to your satisfaction, then write to the Customer Satisfaction Center at the Panasonic Consumer Electronics Company address above.

SERVICE CALLS WHICH DO NOT INVOLVE DEFECTIVE MATERIALS OR WORKMANSHIP AS DETERMINED BY THE WARRANTOR, IN ITS SOLE DISCRETION, ARE NOT COVERED. COSTS OF SUCH SERVICE CALLS ARE THE RESPONSIBILITY OF THE PURCHASER.

warvid 10/20/97

Para ajustar el idioma, canal y reloj

1 Encienda el televisor y la videograbadora.

Presione POWER.

2 Sintonice el televisor al canal de salida de la videograbadora.

(el mismo canal que ha ajustado en la parte trasera de la videograbadora; canal 3 o 4).

- Sintonice siempre el televisor en este canal para obtener la pantalla de videograbadora.
- Si esta usando los terminales de audio/ video para su conexión, ajuste el televisor al modo de entrada de video.

3

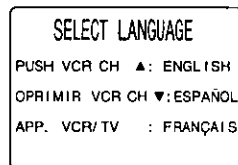

Seleccione el lenguaje.

Presione CH ▲ para elegir el idioma de la pantalla en inglés.

Presione CH ▼ para elegir el idioma de la pantalla en español.

Presione VCR/ TV para elegir el idioma de la pantalla en francés.

4

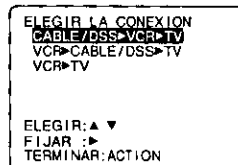

Seleccione la conexión.

- 1) Presione ▲▼ para seleccionar.
- 2) Presione ► para ajustar.

- Si ud. ha elegido CABLE/ DSS ► VCR ► TV, continúe al paso 5 y sólo el canal de salida del cable será memorizado. Si no, a la sección "Instrucciones alternativas" en la página 49.

5

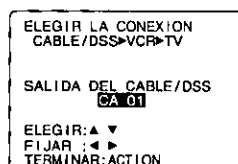

Seleccione la caja de TV por cable o su receptor el canal de salida.

- 1) Presione ▲▼ para seleccionar.
- 2) Presione ► para fijar.

- Si es necesario, consulte su manual de la caja de TV por cable.
- Si esta usando los terminales de audio/ video para su conexión para la caja de TV por cable, ajuste "SALIDA DE VIDEO".

6

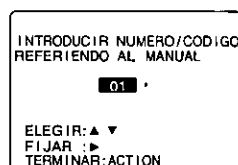

Seleccione el número de código de la caja de TV por cable o el receptor DSS.

(Consulte su lista de la página 7.)

- 1) Presione ▲▼ para seleccionar.
- 2) Presione ► para fijar.

- Si su caja de TV por cable o su receptor DSS no tiene un control remoto, elija "SIN CONTROL REMOTO."
- Luego, vaya a la sección "Instrucciones alternativas" en la página 49.
- De esta manera se determina si el videograbador va a controlar el sintonizador de cable o DSS.

7

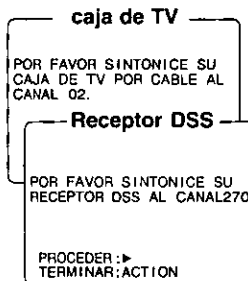

Sintonizar la TV por cable o el canal receptor DSS.

- 1) Si ud. usa una caja de TV por cable, sintonice al canal 2.
Si usa un receptor DSS, sintonice al canal 270.
 - 2) Presione ► para continuar.
- "ESTA TRANSMITIENDO" aparece.

8

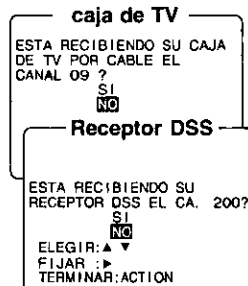

Ajustar canal de recepción.

- 1) Presione ▲▼ para elegir "SI" o "NO."
 - 2) Presione ► para fijar.
- Si ud. usa una caja de TV por cable y ha elegido "SI," siga al paso 9.
Si ud. usa un receptor DSS y ha elegido "SI," siga las instrucciones alternativas de la página 49.

Si ha elegido "NO," aparecerá de nuevo la pantalla del paso 6. Intente elegir un código diferente para su marca y/o cambie la conexión de su equipo.

Si su respuesta es todavía "NO," el control de la caja de TV por cable o el receptor DSS no es disponible.

9

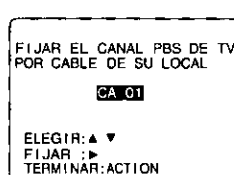

Verifique que su caja de TV por cable esté encendido y su receptor DSS esté apagado.

Seleccione el canal PBS de su local que está recibiendo en su caja de TV por cable.

- 1) Presione ▲▼ para seleccionar.
- 2) Presione ► para ajustar.

10

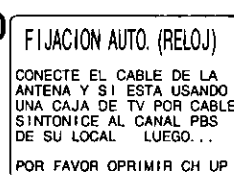

Iniciar la fijación automática del reloj

- Presione ▲.
- "FIJACION AUTOMATICA DE RELOJ EN PROCESO" aparece.

11

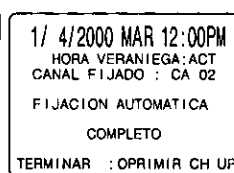

Comprueba si la hora está fijada correctamente.

Presione CH ▲ para terminar la fijación.

Si la hora que aparece no es correcta...

Si en su región se cambia la hora para ahorrar energía, y la hora que aparece es incorrecta, siga los pasos "Ajuste Horario de la Zona."

O, si utiliza la caja de TV por cable y recibe más de una emisora PBS, intente nuevamente el ajuste automático del reloj donde antes no hubiera probado.

Si aparece la pantalla inferior...

La instalación automática del reloj no es de aplicación para su zona horaria.

Pulse ACTION para que aparezca la pantalla "Fijación Manual del Reloj" y siga los pasos b), c) y d) de la página 49.

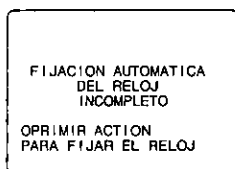

Nota

La fijación automática de la hora se efectuará cada día al apagar la videograbadora por primera vez. therefore, la caja de TV por cable de be permanecer encendido y sintonizado al canal PBS cuando la video grabadora se apaga.

Instrucciones alternativas

Complete los siguientes pasos si ha efectuado una de las siguientes explicaciones.

- Ud. ha elegido la segunda conexión (VCR ► CABLE/ DSS ► TV o VCR ► TV) en el paso 4 de la página 48.
- Ud. ha elegido "SIN CONTROL REMOTO" en el paso 6 de la página 48.
- Ud. Si está usando un receptor DSS y ha elegido "SI" en el paso 8 de la página 48.

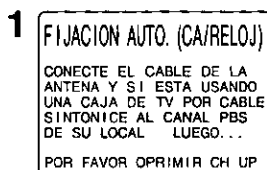

Comience el ajuste automático de canales y el ajuste automático del reloj.

- Aparece las siguientes informaciones:
"AUTOPROGRAMACION EN PROCESO" "FIJACION AUTOMATICA DEL RELOJ EN PROCESO"

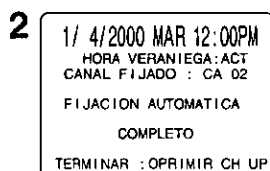

Comprobar si la hora está fijada correctamente.

Presione CH ▲ para salir.

El ajuste del reloj es incompleto.

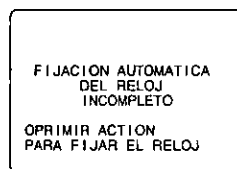

Ajuste el reloj manualmente.

- a) Presione ACTION.
- b) Presione ▲▼ para seleccionar el mes.
- c) Presione ► para ajustar.

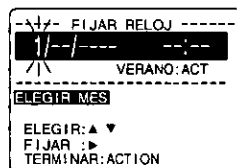

- De la misma manera, ajuste el día, el año, la hora y la hora de ahorro de energía (VERANO). Para hacer correcciones, presione repetidamente ► para moverse hasta el error, luego corríjalo.

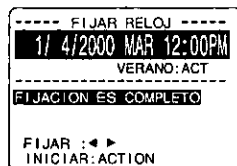

- d) Presione ACTION. (El reloj se activa.)

- Para salir de este modo, pulse la tecla ACTION nuevamente.

Si la hora y la hora veraniega es incorrecta,

Si utiliza la caja de TV por cable y recibe más de una emisora PBS, intente nuevamente el ajuste automático del reloj donde antes no hubiera probado. (vea "Como Reinstalar el Reloj" en la página 40.)

Raras veces, en caso de que ud. vive cerca de dos zonas con hora diferente, el aparato puede elegir un canal PBS con diferente hora de su zona. En este caso, haga los siguientes pasos:

- 1) Tome nota del canal que está fijado en la pantalla y salga desde este modo presione el botón CH ▲.
- 2) Anule este canal desde los canales memorizados en la combinación de VCR/ TV.
- 3) Presione el botón ACTION para que aparezca la pantalla del ACTION.
- 4) Presione ▲▼ para elegir "FIJAR RELOJ" y luego presione ► para que aparezca la pantalla de "FIJAR RELOJ."
- 5) Presione ▲▼ y para elegir y fijar "FIJACION AUTOMATICA."
- 6) Siga las instrucciones en la páginas 48 y 49.

• Si ud. esta usando una caja de TV por cable y tiene muchos canales PBS, sintonize la caja de TV por cable a un canal PBS diferente e intente la fijación automática otravez.

Ajustar de nuevo el reloj

- 1 Presione ACTION para exhiba el menú.

- 2  Presione ▲▼ para seleccionar "FIJAR RELOJ" y luego presione ►.

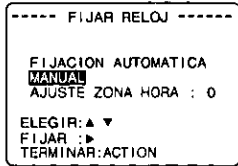
- 3  Presione ▲▼ para seleccionar "MANUAL" y luego presione ►.

- 4  Presione ▲▼ y ◀▶ para seleccionar y ajustar la hora y la fecha.

- 5 Presione ▲▼ y ◀▶ para seleccionar y fijar la hora y la fecha.

- 6 Presione ACTION dos veces para que el reloj comience a funcionar y salir desde este modo.

• Para ajustar el reloj automático, seleccione "FIJACION AUTOMATICA" y luego siga las instrucciones de ajuste de una vez del videograbador en las páginas 48 y 49.

Operaciones básicas para la reproducción

- 1 Inserte un casete.

• La videograbadora se enciende automáticamente.

- 2 Presione PLAY.

• La reproducción comienza si el casete no tiene la lengüeta para prevención de grabación.

- Para encontrar una escena en particular
Búsqueda hacia adelante ---> Presione FF.
Búsqueda hacia atrás ---> Presione REW.

- Para ver en cámara lenta ---> Presione SLOW.

- Para ver una imagen fija (congelada) --->
Presione PAUSE.

- Para ver imágenes cuadro a cuadro --->
Presione SLOW en el modo de imagen fija.

- Para parar ---> Presione STOP.

- Para rebobinar la cinta ---> Presione REW.

- Para expulsar la cinta ---> Presione STOP/EJECT en el videograbadora.

Operaciones básicas para la grabación

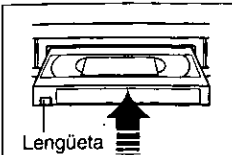
1  **Inserte un casete.**

- La videograbadora se enciende automáticamente.

Lengüeta

2 Seleccione el canal.

Presione CH ▲▼ o las teclas numéricas correspondiente.

3 Seleccione la velocidad de grabación.

Presione SPEED.

- SP = Reproducción estándar,
- LP = Larga duración,
- SLP = Superlarga duración.

4 Comience la grabación.

Presione REC.

- Presione PAUSE para hacer una pausa en la grabación en progreso.

- Para parar ---> Presione STOP.
- Grabación de un toque

Presione REC repetidamente para ajustar la hora de grabación (30 min - 4 horas).

- La videograbadora termina la grabación a una hora programada.

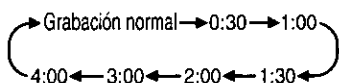

3 Ajuste la fecha de grabación.

FECHA	INICIO	PARADA	CA
7 VIE	--:--	--:--	--
HOY/IN	-----		
CATEGORIA: NO	SLP	-----	
ELEGIR: ▲▼	-----		
FIJAR: ►	-----		
TERMINAR: PROG/ACTION	-----		

- 1) Presione ▲▼ para seleccionar.
- 2) Presione ► o ◀ para ajustar.

- 1-31 = Grabación única
- DIARIO = a la misma hora de lunes a viernes
- SEMANA = a la misma hora una vez a la semana

Ejemplo
Fecha de hoy — 7

8-9	...	31	1	2	...	6
SEMANAL (SAB)	...	SEMANAL (LUN)	...	SEMANAL (DOM)	...	DIARIO

▲/▼ Orden para elegir

Repita el paso 3 para ajustar: hora de comienzo, hora de parada, canal (o LINEA para una fuente exterior), categoría*, velocidad (SP, LP, SLP).

* Categoría
NO, DEPORTE, CINE, COMEDIA, MUSICA, DRAMA

4 Haga las anotaciones necesarias.

FECHA	INICIO	PARADA	CA
8 SAB	10:00P	12:00P	02
HOY	ABC	-----	
CATEGORIA: CINE	SP	-----	
FINICION ES COMPLETO	-----		
PARA REGISTRAR NOTAS: ▲	-----		
FIJAR: ►	-----		

FECHA	INICIO	PARADA	CA
8 SAB	10:00P	12:00P	02
HOY	ABC	-----	
CATEGORIA: CINE	SP	-----	
NOTAS: ◀	-----		
REGISTRAR NOTAS	-----		
ELEGIR: ▲▼	-----		
FIJAR: ►	-----		
TERMINAR: PROG/ACTION	-----		

• Si no fueran necesarias, vaya al paso 5.

- 1) Presione ▲ para hacerlas.
- 2) Presione ▲▼ para seleccionar.
- 3) Presione ◀ para ajustar.
- 4) Presione PROG (o ACTION) para salir.

5 Termine el programa.

P	FE	INIC	PARADA	CA	VEL
1	8	10:00P	12:00P	02	SP
2	---	---	---	---	---
3	---	---	---	---	---
4	---	---	---	---	---

CANCELAR: ADD/DLT
ELEGIR 1-8: ▲▼
ENTRAR: ►
TERMINAR: PROG/ACTION

Presione PROG (o ACTION).

- Si la hora de comienzo de los programas coincide, estos programas se iluminarán.

Si usa un receptor DSS y fija un canal de 100-125, seleccione "DSS" o "CABLE."

ES ESTE EL CANAL DEL TV POR CABLE O DEL RECEPTOR DEL CANAL DSS?	
DSS	
TV POR CABLE	
ELEGIR: ▲▼	-----
FIJAR: ►	-----

- 1) Presione ▲▼ para seleccionar.
- 2) Presione ▲ para fijar.

- La pantalla para la confirmación como demuestrá arriba aparecerá luego de la fijación.

Para introducir más programas, presione ▲▼ y ► para seleccionar y ajustar el número de programa en blanco. Luego repita los pasos 3 y 4.

6 Salir del Programa.

Presione PROG (o ACTION).

6 

Pantalla multifuncional

Grabación con temporizador.

Presione POWER para apagar.

- Si la fuente de la grabación es una caja de TV por cable, asegúrese de que la caja de TV por cable esté encendida y esté sintonizada al canal que desea grabar.

Programación fácil para la grabación con temporizador

1 Exhiba FIJAR PROGRAMACION.

Presione PROG.

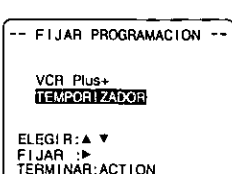
2  **Exhiba "TEMPORIZADOR".**

- 1) Presione ▲▼ para seleccionar.
- 2) Presione ► para exhibir.

- Si ya existe un programa en la memoria, presione ▲▼ y ► para seleccionar un número de programa sin usar.

Location of Controls

Remote control Buttons

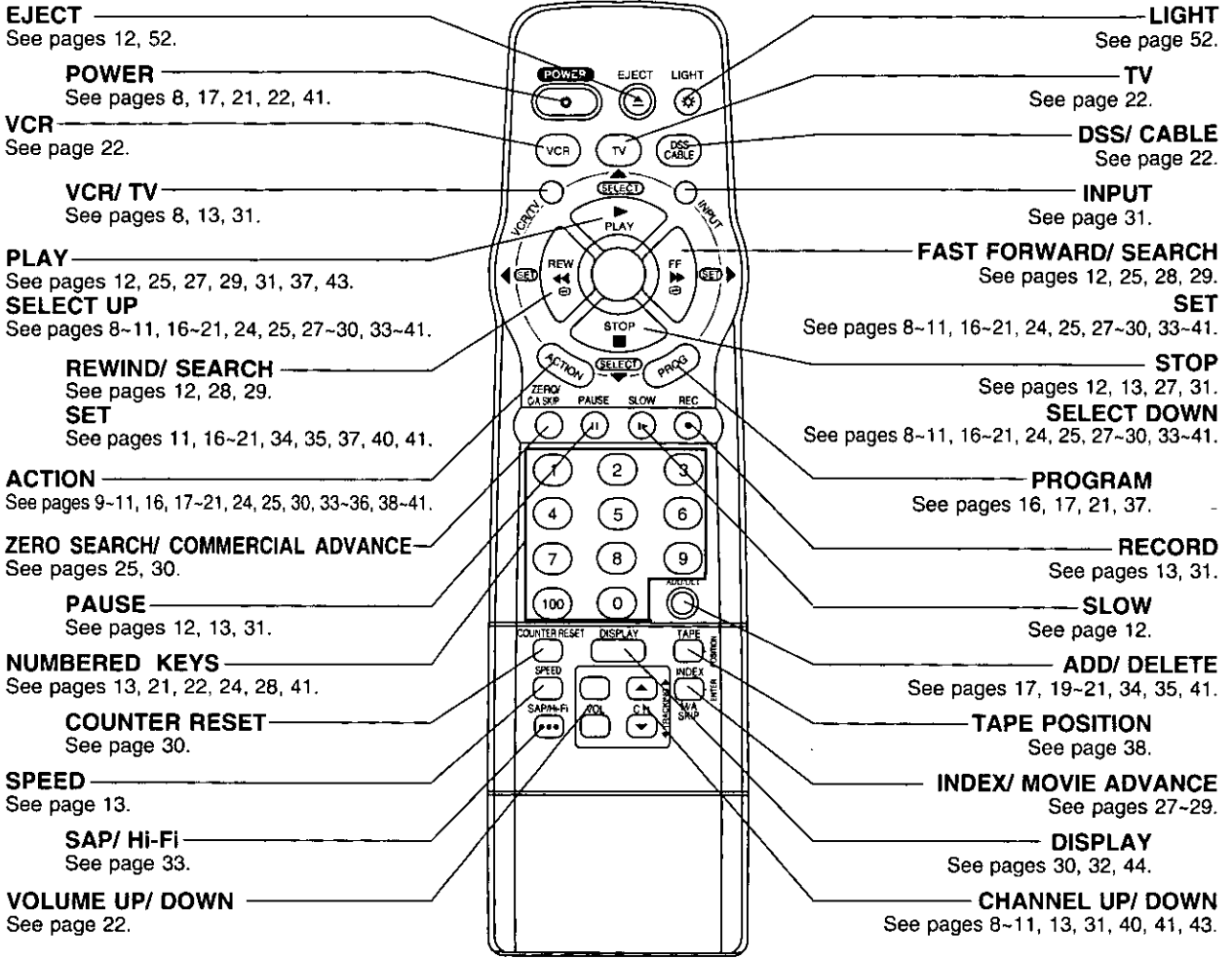

Light Tower Universal Remote Control

Light button: When the LIGHT button is pressed, the buttons which can be activated in the selected mode will light and the selected mode button (TV/VCR or CABLE/DSS) will flash for 5 seconds. If no buttons are pressed within 5 seconds, the light will turn off in order to conserve battery power. Also while holding down the buttons, the selected mode button will flash so you will be able to see, in the dark, which mode has been selected.

EJECT button: When EJECT is pressed, the tape is ejected from Cassette Compartment.
If EJECT is pressed during recording, the VCR will not respond to the command.

Front View of the VCR

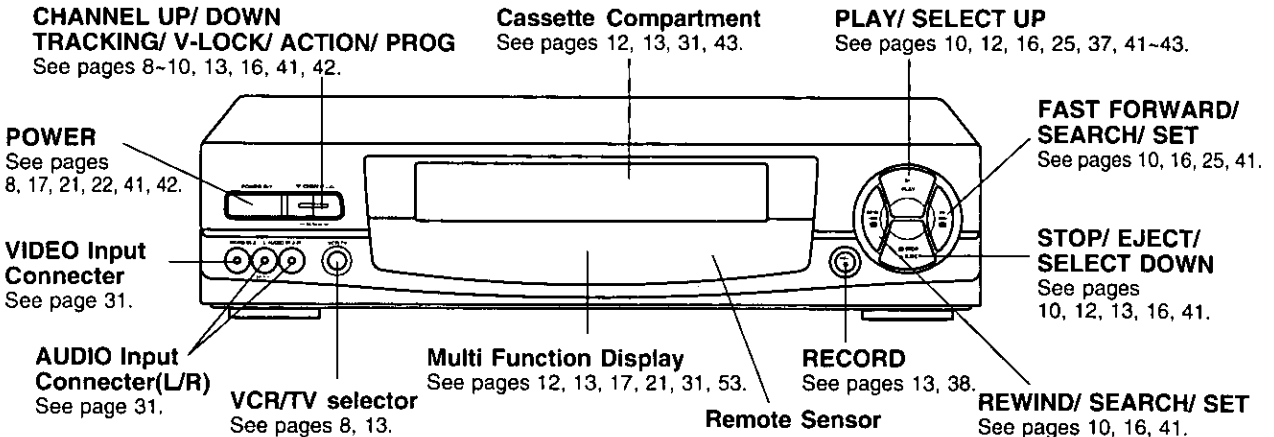

Multi Function Display

Speed Display

Displays the recording speed.

VCR Indicator

Lights when the VCR/TV selector is set to VCR.



Hi-Fi Indicator

Lights when Hi-Fi audio is monitored or playback.

Clock/ Status/ Channel Display

Displays the current time. Briefly displays VCR status when a function button is pressed. Briefly displays the channel number, or "LINE1" or "LINE2" when a channel or line input is selected. In demonstration mode, featured items are displayed. (See below.)

Self Demo Mode

After first power on or VCR memory reset (page 42), Self Demo mode is started after 5 seconds. This mode is cancelled when clock is set. To restart, hold down PLAY on VCR for 5 seconds. To cancel, hold down PLAY again for 5 seconds.

- This mode is only possible when cassette is not inserted and clock is not set.

Rear View of the VCR

AC Power Plug

While plugged into an AC outlet, the VCR consumes 3.3 W of electrical power in OFF condition.

Video Input Connector

See page 31.

Video Output Connector

See pages 15, 31, 32.

VHF/UHF Antenna Input Terminal

See pages 4, 6, 14, 15, 32.

VHF/UHF Antenna Output Terminal

See pages 4, 6, 14, 15, 31, 32.

Channel 3/4 Switch

See pages 4, 8.

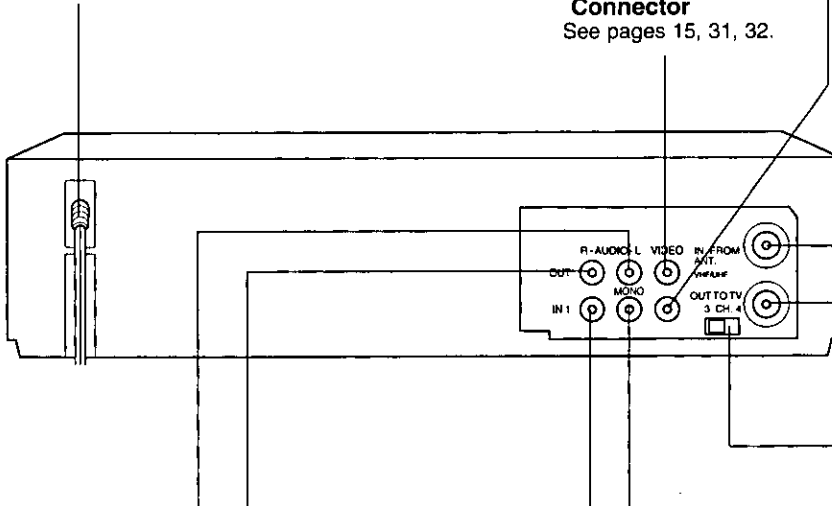

Audio Output Connector (L/R)

See pages 15, 31, 32.

Audio Input Connector (L/R)

See page 31.

Quick Use Guide

Playback a Tape

- 1** Make all connections (page 4).

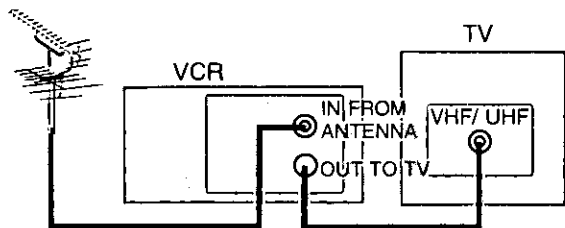

- 2** Set VCR Channel on VCR Rear Panel.

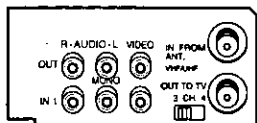

Slide the VCR Channel selector switch to the channel number not used by local broadcast companies (CH3 or 4).

Tune your TV to the channel selected above (3 or 4) whenever you want to see the picture from the VCR on your TV screen.

- 3** Play your Tape.



Insert a tape.

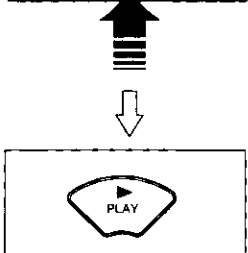

Press PLAY.
(Start playback)

Record on a Tape

- 1** Make all connections (page 4).

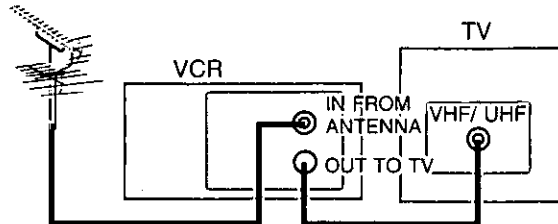

- 2** Set VCR Channel on VCR Rear Panel.

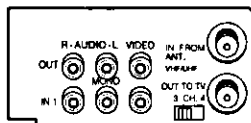

Slide the VCR Channel selector switch to the channel number not used by local broadcast companies (CH3 or 4).

Tune your TV to the channel selected above (3 or 4) whenever you want to see the picture from the VCR on your TV screen.

- 3** Do "One Time VCR Setup" on page 6.

In order for the VCR to properly interface with your equipment, some setup is necessary.

- 4** Record on a Tape.



Insert a tape
with Record Tab.

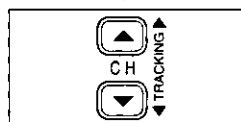

Press CH Up/Down.
(Select Channel)

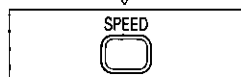

Press SPEED.
(Select speed)

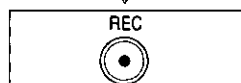

Press REC.
(Start Recording)

Panasonic Consumer Electronics
Company, Division of Matsushita
Electric Corporation of America
One Panasonic Way Secaucus,
New Jersey 07094

Panasonic Sales Company,
Division of Matsushita Electric of
Puerto Rico, Inc. ("PSC")
Ave. 65 de Infanteria, Km. 9.5
San Gabriel Industrial Park, Carolina,
Puerto Rico 00985

Printed in Japan
VQTS3520A

